

کد کنترل

677

C



677C



جمهوری اسلامی ایران
وزارت علوم، تحقیقات و فناوری
سازمان سنجش آموزش کشور

«در زمینه مسائل علمی، باید دنبال قلّه بود.»
مقام معظم رهبری

عصر جمعه
۱۴۰۲/۱۲/۰۴

دفترچه شماره ۳ از ۳

آزمون ورودی دوره‌های دکتری (نیمه‌متمرکز) - سال ۱۴۰۳

آموزش زبان و ادبیات انگلیسی (کد ۲۸۰۵)

مدت زمان پاسخگویی: ۱۰۵ دقیقه

تعداد سؤال: ۲۱۵

عنوان مواد امتحانی، تعداد و شماره سؤال‌ها

ردیف	مواد امتحانی	تعداد سؤال	از شماره	تا شماره
۱	زبان‌شناسی	۱۵	۱	۱۵
۲	سیری بر تاریخ ادبیات انگلیسی ۱ و ۲ - فنون و صناعات	۲۵	۱۶	۴۰
۳	روش تدریس	۱۰	۴۱	۵۰
۴	آزمون‌سازی زبان - روش تحقیق در مسائل آموزش زبان - مسائل آموزش زبان (نظریه‌ها - مهارت‌ها - اصول و روش تدریس - تهیه و تدوین مطالب درسی)	۵۵	۵۱	۱۰۵
۵	نقد ادبی - داستان بلند - دوره‌های ادبی (ادبیات قرن ۱۷ و ۱۸) - شناخت ادبیات - شعر معاصر انگلیسی	۵۵	۱۰۶	۱۶۰
۶	روش تحقیق در ترجمه - نظریه‌های ترجمه - نقد ترجمه - فرهنگ و جامعه‌شناسی در ترجمه	۵۵	۱۶۱	۲۱۵

این آزمون، نمره منفی دارد.

استفاده از فرهنگ لغت مجاز نیست.

* داوطلب گرامی، عدم درج مشخصات و امضا در مندرجات جدول زیر، به منزله عدم حضور شما در جلسه آزمون است.

اینجانب با شماره داوطلبی با آگاهی کامل، یکسان بودن شماره صندلی خود با شماره داوطلبی مندرج در بالای کارت ورود به جلسه، بالای پاسخنامه و دفترچه سؤالها، نوع و کد کنترل درج شده بر روی دفترچه سؤالها و پایین پاسخنامه ام را تأیید می‌نمایم.

امضا:

زبان‌شناسی:

Linguistics (Questions 1 - 15)

- 1- **What is the most accurate definition of a “heritage language”?**
 - 1) A language with which a person has a strong cultural connection through family interaction, but that isn't learned natively.
 - 2) A language with which a person has a strong cultural connection through social interaction and that is learned natively.
 - 3) A language with which a person has a strong cultural connection through family interaction and that is learned natively.
 - 4) A language with which a person has a strong cultural connection through social interaction, but that isn't learned natively.

- 2- **Psycholinguistics is**
 - 1) concerned with linguistic performance or processing, which is the use of linguistic knowledge (competence) in speech production and comprehension
 - 2) concerned with linguistic performance or processing, which is the use of linguistic knowledge (competence) in speech production
 - 3) concerned with linguistic performance or perception, which is the use of linguistic knowledge (competence) in speech comprehension
 - 4) concerned with linguistic performance or perception, which is the use of linguistic knowledge (competence) in speech production and comprehension

- 3- **The word “kine”, the middle English irregular plural of “cow”, has vanished and been replaced by regular “cows” through a process called**
 - 1) leveling
 - 2) equation
 - 3) regularization
 - 4) equilibration

- 4- **“Swim”, basically a verb (as in ‘Can you swim’), may be used as a noun, as in ‘have a swim’. All the following items refer to this process except**
 - 1) Conversion
 - 2) Alteration
 - 3) Functional shift
 - 4) Zero-derivation

- 5- **Lithuanian is a language with a root.**
 - 1) Hellenic
 - 2) Slavic
 - 3) Baltic
 - 4) Italic

- 6- In the sentence “Greyhounds I love very much”, the process of..... can be seen.
1) subject transfer
2) topicalization
3) subject fronting
4) topic movement
- 7- Which statement is FALSE about American Sign Language (ASL)?
1) ASL is a fully developed language, and signers create and comprehend unlimited numbers of new sentences.
2) ASL was introduced by the great educator Thomas Hopkins Gallaudet.
3) ASL is an outgrowth of the sign language used in Britain.
4) ASL was brought to the United States in 1817.
- 8- Which statement is FALSE about the pseudo-writing system?
1) Another name for pseudo-writing is false writing.
2) It can be related to any actual alphabet or spoken language.
3) It is an alphabet made to look real for such purposes as representing alien dialogue in comic strips.
4) It is impossible to say whether authors of pseudo-writing are drawing on their linguistic competence or their artistic muse.
- 9- In English, forms such as [fsɪɡ] or [rɪnɪɡ] do not exist or are unlikely ever to exist due to
1) phonotactic constraints
2) phonological constraints
3) phonemic constraints
4) coarticulation effect
- 10- In Japanese, the use of *suupaa* or *suupaamaaketto* (“supermarket”) and *taipuraitaa* (“typewriter”) can be instances of
1) analogy
2) borrowing
3) backformation
4) loan-translation
- 11- Which of the following is NOT an acronym?
1) Laser
2) Radar
3) Scuba
4) Radio
- 12- is a Japanese syllabary generally used for writing loan words and to achieve the effect of italics.
1) Hiragana
2) Kanji
3) Katakana
4) Kana
- 13- Which statement is the most accurate one about the word “dog”?
1) Dog is a linguistic sign whose form is its letters (d,o,g) and whose meaning is *Canis familiaris* (or however we define “dog”).
2) Dog is a linguistic sign whose form is its concept in the mind and whose meaning is *Canis familiaris* (or however we define “dog”).
3) Dog is a linguistic sign whose form is its part of speech “noun” and whose meaning is *Canis familiaris* (or however we define “dog”).
4) Dog is a linguistic sign whose form is its pronunciation [dag] and whose meaning is *Canis familiaris* (or however we define “dog”).

- 14- Which of the following processes best describes the nature of reduplication (such as “wishy-washy”) in English?
1) Phonological
2) Phonotactic
3) Morphological
4) Morphophonemic
- 15- The notion that certain sound combinations occur in semantically similar words: e.g., [gl] in gleam, glisten, glitter, which all relate to vision is called
1) sound analogy
2) sound symbolism
3) sound initialism
4) sound synchrony

سیری بر تاریخ ادبیات انگلیسی ۱ و ۲ - فنون و صناعات ادبی:

A Survey of the History of English Literature and Literary Terms (Questions 16 - 40)

- 16- Who coined the phrase “willing suspension of disbelief”?
1) John Keats
2) Charles Lamb
3) T. S. Eliot
4) Samuel Taylor Coleridge
- 17- One reason why “Mystery Plays” are referred to as such is because they
1) were sponsored by the guilds known as “mysterie”
2) explore mysterious and religious topics
3) were written by medieval mystics
4) involve the solving of a crime
- 18- What word did neoclassical writers use to express quickness of mind?
1) Sprezzatura
2) Conceit
3) Gusto
4) Wit
- 19- A picaresque novel dramatizes the life of
1) a member of the middle class engaging in self-exploration
2) a child as he or she develops into an adult
3) a lowborn, wandering adventurer
4) a member of the royalty
- 20- Which of the following excerpts contains “synesthesia”?
1) Season of mists and mellow fruitfulness, / Close bosom-friend of the maturing sun; /
Conspiring with him how to load and bless / With fruit the vines that round the thatch-
eaves run;
2) And the hyacinth purple, and white, and blue, / Which flung from its bells a sweet
peal anew / Of music so delicate, soft, and intense, / It was felt like an odor within
the sense.
3) So let us melt, and make no noise, / No tear-floods, nor sigh-tempests move; / ‘Twere
profanation of our joys, / To tell the laity our love.
4) Round the cape of a sudden came the sea, / And the sun looked over the mountain’s rim: /
And straight was a path of gold for him, / And the need of a world of men for me.

- 21- Which of the following works is the passage below correct about?
The poem's plot involves a folklore motif of a challenge by a supernatural visitor, first found in an Old Irish tale. The poet has made this motif a challenge to King Arthur's court and has framed the tale with allusions at the beginning and end to the legends that link Arthur's reign with the Trojan War and the founding of Rome and of Britain. The poet has a sophisticated awareness of romance as a literary genre and plays a game with both the hero's and the reader's expectations of what is supposed to happen in a romance.
- 1) Morte d'Arthur
 - 2) Charlemagne and his Knights
 - 3) Troilus and Criseyde
 - 4) Sir Gawain and the Green Knight
- 22- Which work captures a sense of the political turmoil, particularly regarding the issue of religion, just after the Restoration?
- 1) Gay's *The Beggar's Opera*
 - 2) Dryden's *Absalom and Achitophel*
 - 3) Butler's *Hudibras*
 - 4) Fielding's *Jonathan Wild*
- 23- The poet of "Bright Star", "To Autumn", and "On First Looking into Chapman's Homer" also wrote
- 1) Ode to a Little Invisible Being
 - 2) Ode to the West Wind
 - 3) Ode to a Nightingale
 - 4) Ode to Duty
- 24- Which "poet: poem" does the following excerpt describe?
The poem depicts the growth of a woman poet and is thus the first work in English by a woman writer in which the heroine herself is an author.
- 1) Elizabeth Barret Browning: Aurora Leigh
 - 2) Christina Rossetti: Winter: My Secret
 - 3) George Eliot: Count That Day Lost
 - 4) Emily Bronte: Remembrance
- 25- Which of the following is NOT a Poem by Mathew Arnold?
- 1) Sohrab and Rostum: An Episode
 - 2) The Scholar-Gipsy
 - 3) Tears, Idle Tears
 - 4) Dover Beach
- 26- Which of the following illustrates the events in the 16th century in the correct chronological order from the earliest to the latest?
- 1) Henry VIII as Head of the English Church → Henry VIII named as "Defender of the Faith" → Thomas More as Lord Chancellor → Martin Luther's Wittenberg Theses
 - 2) Martin Luther's Wittenberg Theses → Henry VIII named as "Defender of the Faith" → Thomas More as Lord Chancellor → Henry VIII as Head of the English Church
 - 3) Thomas More as Lord Chancellor → Martin Luther's Wittenberg Theses → Henry VIII as Head of the English Church → Henry VIII named as "Defender of the Faith"
 - 4) Henry VIII named as "Defender of the Faith" → Martin Luther's Wittenberg Theses → Henry VIII as Head of the English Church → Thomas More as Lord Chancellor
- 27- In the late seventeenth century, a "battle of the books" erupted between two groups, namely, the
- 1) adherents of Enlightenment and the Anglican church
 - 2) advocates of ancient and modern learning
 - 3) satirists and the novelists
 - 4) empiricists and the sophists

- 28- **Name the author who collaboratively wrote *Tales from Shakespeare*.**
- 1) Charles Lamb
 - 2) Robert Southey
 - 3) William Hazlitt
 - 4) Thomas De Quincey
- 29- **Which of the following is NOT an 18th-century literary event?**
- 1) Horace Walpole published *The Castle of Otranto*.
 - 2) Kant wrote his *Critique of the Power of Judgment*.
 - 3) William Wordsworth's *The Prelude* was published.
 - 4) With the help of a few others, Thomas Jefferson composed "The Declaration of Independence."
- 30- **Which of the following is NOT correct about John Skelton?**
- 1) He was a disgruntled courtier, political pamphleteer, visionary, biting satirist, and ordained priest.
 - 2) C. S. Lewis believes John Skelton had "no real predecessors and no important disciples."
 - 3) His poetry draws on a long tradition of medieval anticlerical satire and carnivalesque parody.
 - 4) He writes in long rhymed lines, using a remarkable amount of figurative language.
- 31- **Which of the following is NOT correct about John Milton's *Lycidas*?**
- 1) It incorporates a furious apocalyptic diatribe on the corrupt Church of England clergy.
 - 2) It is a pastoral elegy commemorating the death of his college classmate, Edward King.
 - 3) It defends the revolution and is particularly important in "contact theory."
 - 4) It explores Milton's deep anxieties about poetry as a vocation.
- 32- **Which of the following is NOT correct about Ben Jonson?**
- 1) In the poem "Inviting a Friend to Supper," he comes to enumerate and admire divine values.
 - 2) His "To Penshurst" inaugurated the small genre of the "country house poem."
 - 3) He was called before the Privy Council to answer charges of popery and treason found in his play *Sejanus*.
 - 4) He rose from very humble beginnings to become England's unofficial poet laureate.
- 33- **Which of the following is NOT correct about King Alfred?**
- 1) He translated the *Consolation of Philosophy* into English.
 - 2) He translated various works from Latin, the most important of which was *Confessio Amantis*.
 - 3) He stopped the Dane invaders and united all the kingdoms of southern England.
 - 4) He probably instigated a translation of Bede's *History* and the beginning of the *Anglo-Saxon Chronicle*.
- 34- **Which of the following is NOT correct about the Renaissance style?**
- 1) Erasmus's *De Copia* was written to teach its readers how to cultivate plainness and avoid verbal prolixity.
 - 2) Renaissance literature is the product of a rhetorical culture, a culture steeped in the arts of persuasion.
 - 3) Elizabethans had a taste for elaborate and perfectly intricate music, gardens, and architectural designs.
 - 4) Renaissance culture is trained to process complex verbal signs, and syntactic forms or patterns of words were shaped and repeated.

- 35- **Which of the following is NOT correct about Sir Thomas More?**
- 1) With Erasmus, he shared an ardent Christian piety, a suspicion of scholastic hair-splitting, and a delight in rhetoric.
 - 2) His masterpiece, *Utopia*, displays the strong influence of Plato's *Republic*, with its radically communalistic reimagining of society.
 - 3) Middle-class liberals have admired his vision of free public education, careers open to talents, and freedom of thought.
 - 4) In *The History of King Richard III*, unlike Shakespeare, he sympathizes with Richard III and appreciates his honesty.
- 36- **Which of the following is NOT correct about Medieval Lays?**
- 1) They originate from Breton storytellers.
 - 2) They affected the rise of medieval drama.
 - 3) They were composed in the Anglo-Norman period.
 - 4) Marie de France's *Lanval* and *Chevroil* are two dominant examples of the genre.
- 37- **Which of the following ends a poem by W. B. Yeats?**
- 1) Are you the leaf, the blossom, or the bole? / O body swayed to music, O brightening glance, / How can we know the dancer from the dance?
 - 2) But no longer at ease here, in the old dispensation, / With an alien people clutching their gods. / I should be glad of another death.
 - 3) Let the healing fountain start, / In the prison of his days / Teach the free man how to praise.
 - 4) Between my finger and my thumb / The squat pen rests. / I'll dig with it.
- 38- **Which of the following about Christopher Marlowe (1564-1593) is correct?**
- 1) Unlike Barabas, the Jew of Malta, who seeks mastery and voluptuous pleasure from forbidden knowledge, Marlowe's Faustus lusts for "infinite riches in a little room."
 - 2) His "The Nymph's Reply to the Shepherd" is one of the most famous Elizabethan songs, and a few lines from it are sung in Shakespeare's *Love's Labour's Lost*.
 - 3) His *Tamburlaine* is the vehicle for the expression of boundless energy and ambition, the impulse to strive ceaselessly for absolute dominance.
 - 4) Marlowe's mythological *Venus and Adonis* is a free and original treatment of a classic tale about two ill-fated lovers.
- 39- **Which of the following is correct about the Revolutionary era (1640-1660) and its literature?**
- 1) In *Areopagitica* (1644), John Milton argues vigorously for press censorship and toleration of Catholics.
 - 2) The commercial theaters were profitable businesses that made most of their money from paying audiences.
 - 3) The Presbyterians, Congregationalists, Independents, Baptists, and other separatists supported a national church.
 - 4) While most writers during this period were royalists, two of the best, Andrew Marvell and John Milton, sided with the republic.

- 40- Which of the following statements about John Bunyan (1628–1688) is correct?
- 1) Bunyan was born to English parents in Dublin as a posthumous child.
 - 2) Bunyan's *Pilgrim's Progress* expressed the conscience of a Nonconformist.
 - 3) In *A Tale of a Tub*, Bunyan's powerful satire addresses the corruption in religion and learning.
 - 4) Bunyan turned annual fairs into an allegory of universal spiritual significance in *Grace Abounding to the Chief of Sinners*.

روش تدریس:

Teaching Methodology (Questions 41 - 50)

- 41- Which item is NOT an advantage of "recorded oral feedback" in writing classes?
- 1) Helping with a more positive interpretation of comments through non-verbal features
 - 2) Providing opportunity for negotiation and discussion
 - 3) Being accessible to students to listen to multiple times
 - 4) Being quicker than providing written feedback
- 42- Which one is NOT a purpose of reflective teaching?
- 1) Increasing knowledge of theories of teaching
 - 2) Increasing understanding of teaching-learning processes
 - 3) Expanding language teachers' repertoire of strategic options
 - 4) Improving the quality of learning opportunities in classrooms
- 43- Whole Language method adopts a/an perspective towards language.
- 1) cultural
 - 2) functional
 - 3) structural
 - 4) interactional
- 44- Which method of language teaching draws on behavioral psychology?
- 1) Total Physical Response
 - 2) Audiolingual Method
 - 3) Natural Approach
 - 4) Suggestopedia
- 45- Which item is NOT a challenge of ethnographic research into second language?
- 1) Various research instruments are needed to ensure triangulation of data.
 - 2) More than one researcher is needed to ensure data verification.
 - 3) Ethnographic findings are not widely accepted.
 - 4) Ethnographies usually take a long time to complete.
- 46- All of the following programs are types of bilingual approaches to language teaching EXCEPT
- 1) task-based training
 - 2) newcomer program
 - 3) heritage language
 - 4) vocational training
- 47- What are the three key curricular processes that are in play at every level of the curriculum, be it a program, a course, a unit, or a lesson?
- 1) Analysis, planning, execution
 - 2) Acting, assessing, replanning
 - 3) Planning, enacting, evaluating
 - 4) Planning, implementing, replanning

- 48- According to Benson, in order to promote autonomous learning, a teacher should adhere to all of these principles EXCEPT
- 1) encouraging reflection
 - 2) providing resources and options
 - 3) developing learning strategies
 - 4) offering decision-making opportunities
- 49- The information structures which are related to brain's information processing system and are stored in working and long-term memories are described as competence.
- 1) performance
 - 2) technical
 - 3) functional
 - 4) strategic
- 50- Which item is shared among the teaching approaches that follow the central design?
- 1) They give priority to the role of learner in creating learning opportunities.
 - 2) They consider learning input as the starting point in curricular development.
 - 3) They follow the outcome-assessment-content pattern.
 - 4) They do not prioritize classroom participation.

آزمون‌سازی زبان - روش تحقیق در مسائل آموزش زبان - مسائل آموزش زبان (نظریه‌ها - مهارت‌ها - اصول و روش تدریس - تهیه و تدوین مطالب درسی):

Testing (Questions 51 - 65)

- 51- Data from MTMM correlation matrices can be analyzed in all the following ways EXCEPT
- 1) path analysis
 - 2) the analysis of variance
 - 3) confirmatory factor analysis
 - 4) the direct inspection of convergent and discriminant correlations
- 52- In language tests, the issue of bias is complicated by the problem of clearly distinguishing elements of and from the language abilities we want to measure.
- 1) academic background - academic subject
 - 2) culture - educational background
 - 3) content - academic background
 - 4) culture - content
- 53- is the statistical process of demonstrating the equivalence or at least the exact psychometric relation of two versions of a test, particularly how difficult they are.
- 1) Test leveling
 - 2) Test equating
 - 3) Test balancing
 - 4) Test synchronizing
- 54- What procedure can be used in the development of computer adaptive tests which measure the growth of individuals over time?
- 1) Trialing
 - 2) Item difficulty
 - 3) Test linking
 - 4) Data matrix

- 55- **In the framework of test method facets, the testing environment includes the following facets EXCEPT**
- 1) the time of testing
 - 2) practical conditions
 - 3) the personnel involved in the test
 - 4) familiarity of the place and equipment used in administering the test
- 56- **What is the primary goal of distractor efficiency analysis?**
- 1) to examine the degree to which the distractors are attracting students who know the correct answer
 - 2) to examine the degree to which the distractors are attracting students who doubt to choose the correct answer
 - 3) to examine the degree to which the distractors are attracting students who do not know the correct answer
 - 4) to examine the degree to which the distractors are attracting students who know and do not know the correct answer
- 57- **Which test-centered method for standard setting is only appropriate for multiple-choice tests?**
- 1) Ebel method
 - 2) Jaeger method
 - 3) Anghoff method
 - 4) Nedelsky method
- 58- **What is a common technique for rater training in rater-mediated assessment?**
- 1) Mediation
 - 2) Mentoring
 - 3) Monitoring
 - 4) Moderation
- 59- **Regarding establishing the authenticity of a test, one important constraint on direct knowledge of the criterion is the**
- 1) Observer's paradox
 - 2) Hawthorn effect
 - 3) Practice effect
 - 4) Halo effect
- 60- **Using distorted messages is an appropriate technique for testing**
- 1) listening comprehension
 - 2) reading comprehension
 - 3) speaking
 - 4) writing
- 61- **Free writing is usually effective for and levels of proficiency.**
- 1) beginner - elementary
 - 2) intermediate - beginner
 - 3) elementary - intermediate
 - 4) intermediate - advanced
- 62- **In a passage with some deletions is given to the testees, but read in complete form.**
- 1) Dicto-comp
 - 2) Partial dictation
 - 3) Elicited imitation
 - 4) Dictation with competing noise
- 63- **..... are used in situations where the medium of instruction is a language other than the learners' mother tongue.**
- 1) Selection tests
 - 2) Proficiency tests
 - 3) Knowledge tests
 - 4) Achievement tests
- 64- **How many descriptions of proficiency levels are there in ACTFL proficiency guidelines?**
- 1) 7
 - 2) 8
 - 3) 9
 - 4) 10

- 65- To do, testers need to develop two parallel forms (for instance, forms A and B) of the CRT so that they are very similar, objective-by-objective. During the pretest, half of the students (randomly selected) take Form A and half take Form B. After instruction, the first half then takes Form B and the second half takes Form A.
- 1) counter-balancing
 - 2) intervention studies
 - 3) differential-groups studies
 - 4) standard setting method

Research Methodology (Questions 66 - 80)

- 66- What research design can be considered for the following condition?
To answer the question, "What is the effect of part-time work on school achievement of high school students?" The researcher would not manipulate the lives of high school students by having some take part-time jobs and others not; instead, the researcher would identify students who already work part-time and compare their achievement with that of students who do not work.
- 1) case study
 - 2) correlational research
 - 3) descriptive research
 - 4) ex post facto research
- 67- Which item is FALSE about the effect size?
- 1) Effect size is dependent on sample size. Therefore, large effect sizes cannot easily be observed through chance alone with very small samples.
 - 2) Effect sizes are interpreted in the same way that z scores are interpreted.
 - 3) Effect size has a universal meaning to assess both the direction and the strength of a difference between two means.
 - 4) One approach is to ask if a given effect size is larger or smaller than effect sizes found in other studies with the same dependent variable.
- 68- In an ANOVA-based study, η^2 is equal to 0.7. What does it show?
- 1) A large effect size
 - 2) A small effect size
 - 3) A medium effect size
 - 4) It is not possible to decide on the effect size.
- 69- What instrument can be used to measure the aptitude of individuals in a research study?
- 1) Cognitive Abilities test
 - 2) Test of Cognitive Skills
 - 3) Stanford-Binet test
 - 4) Otis-Lennon School Ability test
- 70- The can be a problem in educational research that compares exciting new teaching methods with conventional methods.
- 1) Halo effect
 - 2) Hawthorne effect
 - 3) Multiplier effect
 - 4) Boundary effect

- 71- **What research design can be used for the following condition?**
 Assume that an elementary teacher wants to evaluate the effectiveness of a new technique for teaching fourth-grade math. At the beginning of the school year, the students are given a standardized test (pretest) that appears to be a good measure of the achievement of the objectives of fourth-grade math. The teacher then introduces the new teaching technique and at the end of the semester administers the same standardized test (posttest), comparing students' scores from the pretest and posttest in order to determine if exposure to the new teaching technique made any difference.
- 1) Static Group Comparison
 - 2) One-Group Pretest-Posttest Design
 - 3) Randomized Subjects, Posttest-Only Control Group Design
 - 4) Non-randomized Subjects, Posttest-Only Control Group Design
- 72- is a technique used to determine what correlation remains between two variables when the effect of another variable is eliminated.
- 1) Point-biserial correlation
 - 2) Tetrachoric correlation
 - 3) Partial correlation
 - 4) Phi correlation
- 73- **What kind of research study does the following paragraph refer to?**
 A school system might follow the high school graduating class(es) of 2004 over time and ask them questions about higher education, work experiences, attitudes, and so on. From a list of all the graduates, a random sample is drawn at different points in time, and data are collected from that sample. Thus, the population remains the same during the study, but the individuals surveyed are different each time.
- 1) Panel study
 - 2) Trend study
 - 3) Cohort study
 - 4) Ex post facto research
- 74-, grounded in philosophy, attempts to examine lived experience through three in-depth interviews, with the first focused on the past, the second on the present, and the third on connecting the previous two to understand the "essential" experience.
- 1) Phenomenological interviewing
 - 2) Ethnographic interviewing
 - 3) Focus group interviewing
 - 4) Elite interviewing
- 75- **What kind of coding is NOT a common coding technique in grounded theory studies?**
- 1) Real-time coding
 - 2) Open coding
 - 3) Axial coding
 - 4) Selective coding
- 76- **Structural equation modeling is a statistical procedure, combining and, to test a researcher's theoretical model that involves both observed and unobserved (or latent) variables.**
- 1) Exploratory factor analysis - Multiple regression analysis
 - 2) Confirmatory factor analysis - Cluster analysis
 - 3) Cluster analysis - Multiple regression analysis
 - 4) Path analysis - Confirmatory factor analysis
- 77- **What type of action research involves collaboration among stakeholders in a social process?**
- 1) Critical action research
 - 2) Classroom action research
 - 3) Collaborative action research
 - 4) Participatory action research

- 78- **Why do researchers often turn to the time-series design?**
- 1) Because of the problems involved with pre-testing and the difficulties in finding control groups that match the experimental group.
 - 2) Because of the problems involved with post-testing and the difficulties in finding control groups that match the experimental group.
 - 3) Because of the problems involved with transient research and the difficulties in finding control groups that match the experimental group.
 - 4) Because of the problems involved with random assignment and the difficulties in finding control groups that match the experimental group.
- 79- **Which test is NOT a multiple-range test?**
- 1) Tukey
 - 2) Scheffe
 - 3) Friedman
 - 4) Newman-Keuls
- 80- **What is the use of MANCOVA in educational research?**
- 1) a multivariate extension of univariate ANOVA to experimental situations where there are multiple dependent variables.
 - 2) a multivariate extension of univariate ANOVA to experimental situations where there are multiple independent variables.
 - 3) a multivariate extension of univariate ANOVA to experimental situations where there is one dependent variable.
 - 4) a multivariate extension of univariate ANOVA to experimental situations where there is one independent variable.

Teaching Methodologies (Questions 81 - 105)

- 81- **One proficiency framework or model that arose alongside CLT was the American Council on the Teaching of Foreign Languages (ACTFL) Standards for Foreign Language Learning for the 21st Century, also known as the Five Cs model. The model contains all the following components EXCEPT**
- 1) Contexts
 - 2) Connections
 - 3) Communities
 - 4) Comparisons
- 82- **The negotiated syllabus grew out of the**
- 1) Lexical syllabus
 - 2) Task-based syllabus
 - 3) Genre/text-based syllabus
 - 4) Notional-functional syllabus
- 83- **In (the), students need to become independent, self-regulated learners. Self-assessment leads to learner autonomy.**
- 1) participatory approach
 - 2) multiple intelligences
 - 3) learning strategy training
 - 4) task-based language teaching
- 84- **Diane Larsen-Freeman (1997) warns TEFL experts and researchers to avoid reductionist thinking to**
- 1) emphasize the link between chaos theory and SLA
 - 2) show how methods of language teaching should be analyzed
 - 3) invite researchers to think more cautiously about research gaps
 - 4) criticize the TEFL community due to the small number of theories in the field

- 85- **How many stages does culture shock have and at what stage does “culture stress” take place?**
 1) 5 stages - Stage 1
 2) 4 stages - Stage 2
 3) 5 stages - Stage 4
 4) 4 stages - Stage 3
- 86- **In Long’s (1985, 1996) view, and are two major players in the process of acquisition.**
 1) intake - modification
 2) interaction - output
 3) modification - output
 4) input - interaction
- 87- **The “standards” movement which has dominated educational discussions since the 1990s in the US is based on**
 1) CBI
 2) CLT
 3) CBLT
 4) TBLT
- 88- **In teaching speaking, all the following are the components of speaking competence according to Celce-Murcia et al., EXCEPT**
 1) Strategic skills
 2) Interactional skills
 3) Phonological skills
 4) Speech function skills
- 89- **..... combines wide-angled and narrow-angled approaches. Initially, students from different vocations are in one classroom. They study all four skills (listening, speaking, reading, and writing), often in a theme-based program.**
 1) VESL model
 2) Cluster VESL
 3) Workplace VESL
 4) Pre-employment VESL
- 90- **Which item is NOT a feature of extensive reading in TEFL?**
 1) Teachers read with students
 2) Students read a limited amount of material
 3) Students usually take part in post-reading activities
 4) Reading materials vary in terms of topic and genre
- 91- **Which item is NOT a feature of real-world listening input?**
 1) The use of facilitation devices
 2) The use of compensation devices
 3) The use of time-creating devices
 4) The use of comprehension devices
- 92- **In MI, story-telling and memorizing are suitable for students with intelligence and conflict mediations are suitable for students with intelligence and field trips are suitable for students with intelligence.**
 1) intrapersonal – bodily – spatial
 2) logical – bodily – interpersonal
 3) logical – interpersonal – spatial
 4) linguistic – interpersonal – bodily
- 93- **Which item is NOT a stage of intellectual development in children?**
 1) Sensorimotor stage
 2) Preoperational stage
 3) Concrete operational stage
 4) Abstract Operational stage
- 94- **Based on O’Malley’s classification of learning styles, which of the following is a metacognitive strategy?**
 1) Contextualization
 2) Delayed production
 3) Question for clarification
 4) Auditory representation

- 95- **Which statement is FALSE regarding intake processes?**
- 1) The intake processes that appear to shape L2 development may be grouped under four broad and overlapping categories: inferencing, structuring, restructuring, and mental representing.
 - 2) As procedures and operations that are internal to the learner, intake processes remain the most vital and the least understood link in the input–intake–output chain.
 - 3) Intake processes consist of mental operations that are specific to language learning as well as those that are required for general problem-solving activities.
 - 4) Intake processes are cognitive mechanisms that at once mediate between, and interact with, input data and intake factors.
- 96- enables one to predict the course of development of L2 linguistic forms in language production and comprehension across languages.
- 1) Natural order hypothesis
 - 2) Lexical mapping theory
 - 3) Processability theory
 - 4) Learnability theory
- 97- **According to Gardner, what do traditional IQ tests measure?**
- 1) Logic and reasoning
 - 2) Logic and language
 - 3) Mathematics and logic
 - 4) Geometry and language
- 98- **What is the most important weakness of the lexical approach?**
- 1) Its learning theory
 - 2) Its language theory
 - 3) Its syllabus
 - 4) Its design
- 99- **Which of the following is a variable characteristic of ESP according to Dudley-Evans and St John (1998)?**
- 1) ESP is in contrast with General English
 - 2) ESP is designed to meet the specified needs of the learner
 - 3) ESP is not taught according to any pre-ordained methodology
 - 4) ESP is related in content (i.e., in its themes and topics) to particular disciplines, occupations and activities (and contexts)
- 100- **All of the following are examples of teaching and learning activities for the revising phase of the writing process in the instruction of writing EXCEPT**
- 1) reorganizing
 - 2) adding details
 - 3) proofreading practice
 - 4) adding support for arguments
- 101- **What method of language teaching is linked to “language alternation”?**
- 1) Suggestopedia
 - 2) The silent way
 - 3) Grammar translation method
 - 4) Community language learning
- 102- **Which of the following strategies CANNOT be a “cognitive strategy”?**
- 1) Literal translation
 - 2) Grouping
 - 3) Resourcing
 - 4) Note-taking
- 103- **What is another name for Ausubel’s “subsumption” in McLaughlin’s attention-processing model?**
- 1) Structuring
 - 2) Construction
 - 3) Restructuring
 - 4) Reconstruction

- 104- Choose the item that divides the early years of ESP respectively.
- 1) 1. Discourse analysis 2. register analysis 3. skills and strategies 4. target situation analysis 5. learning-centered approach
 - 2) 1. Register analysis 2. discourse analysis 3. target situation analysis 4. skills and strategies 5. learning-centered approach
 - 3) 1. Register analysis 2. discourse analysis 3. skills and strategies 4. target situation analysis 5. learning-centered approach
 - 4) 1. Discourse analysis 2. register analysis 3. target situation analysis 4. skills and strategies 5. learning-centered approach
- 105- All of the following are guidelines for explicit strategy instruction EXCEPT
- 1) Transfer
 - 2) Extension
 - 3) Task completion
 - 4) Awareness-raising

نقد ادبی - داستان بلند - دوره‌های ادبی (ادبیات قرن ۱۷ و ۱۸) - شناخت ادبیات - شعر معاصر انگلیسی:

Literary Criticism and Philosophy of Literature (Questions 106 - 128)

- 106- The term “Anagnorisis,” as used by Aristotle in his *Poetics*, refers to the hero’s
- 1) recognition of something of great importance
 - 2) ignorance about his tragic flaw
 - 3) recognition of his adversary
 - 4) recognition of his tragic end
- 107- Which of the following critics argues against the view that history is, at best, a marginal concern in postmodernist literature?
- 1) Perry Anderson
 - 2) Patricia Waugh
 - 3) Linda Hutcheon
 - 4) Ihab Hassan
- 108- One of the founders of literary Darwinism was, whose concept of *consilience*, or the unity of knowledge – especially between the sciences and humanities – dates back to the ancient Greek sense of the unity of the cosmos and was widely discussed by philosophers of science during the Enlightenment.
- 1) D. T. Max
 - 2) E. O. Wilson
 - 3) Charles Darwin
 - 4) Frederick Crews
- 109- “Critical concept: critic/theorist” match EXCEPT in
- 1) The Signifying Monkey: Henry Louis Gates Jr.
 - 2) Semiotic Square: A. J. Greimas
 - 3) Distant Reading: Jerome McGann
 - 4) Cyborg: Donna Haraway
- 110- A diegetic narrator is one who
- 1) just tells the story in the action in which he/she does not participate
 - 2) directly reports the events of the story to the readers
 - 3) speaks in the voice of another character in the story
 - 4) also participates in the story he/she tells

- 111- All the following are correct about Roland Barthes' critical notions EXCEPT that
- 1) he assumes two simultaneously functioning dimensions for the narrative: retrospective and prospective
 - 2) he theorizes that myth's fundamental principle is to transform history into nature
 - 3) he postulates that, in signification, departures are more important than arrivals
 - 4) he favors the idea of the "work" over the concept of the "text"
- 112- "Theory: theorist" correctly match only in
- 1) the idea of postmodern pastiche as blank parody: Fredric Jameson
 - 2) the idea of the postmodern as the era of the ob-scene rather than the scene: Hal Foster
 - 3) the idea of postmodernism as a new form of Western cultural imperialism: Homi K. Bhabha
 - 4) the idea of postmodernism as an intellectual camouflage for neo-Marxist ideas: Brian McHale
- 113- Which of the following best describes the term *flâneur*?
- 1) A bourgeois character with a unique blend of middle-class aspirations and societal norms
 - 2) A decadent figure in art, epitomizing opulence and transcending conventional norms
 - 3) An emblematic figure of modernity, a frequenter and consumer of the city streets
 - 4) A narrator whose perspective is closely identifiable with that of the author
- 114- *Semanalysis* refers to
- 1) Charles Morris's syncretic formulation of semiotics
 - 2) Julia Kristeva's vision of an analytical semiotics
 - 3) Jury Lotman's culturally oriented semiotics
 - 4) the Peircean tradition of semiotics
- 115- "Critic: term" match in all the following EXCEPT
- 1) Edward Said: imaginative geography
 - 2) Michel Foucault: author function
 - 3) Wolfgang Iser: implied reader
 - 4) Jacques Derrida: rhizome
- 116- "Theoretical text: author" match in all the following EXCEPT
- 1) *Of Grammatology*: Ronald Barthes
 - 2) *Allegories of Reading*: Paul de Man
 - 3) *A Literature of their Own*: Elaine Showalter
 - 4) *The Production of Space*: Henri Lefebvre
- 117- Concerning the readers' view of literature, hermeneutic theory mainly suggests that it is NOT possible to
- 1) interpret a piece of literature accurately, recognizing the limitations imposed by the hetero-normative paradigm
 - 2) interpret a piece of literature according to the author's original intent
 - 3) isolate a text from the linguistic rules that constitute it
 - 4) disentangle a text from capitalist ideology

- 118- **What does the term “aporia” designate in the context of deconstruction theory?**
- 1) The notion that a text possesses a particular meaning that becomes discernible through a process of deconstruction
 - 2) The concept that language is intertwined with the social lives and historical context of its speakers
 - 3) The inherent indecisiveness and fundamentally unstable character of a text
 - 4) The capacity of a text to encompass truth
- 119- **Which idea relates to J. L. Austin’s performativity theory?**
- 1) Performance is the ultimate objective of all human beings.
 - 2) Language is used to indicate action as well as thought.
 - 3) Readers participate in creating the meaning of a text.
 - 4) Individuals perform gender actively.
- 120- **Which of the following is NOT correct about the second wave of feminism?**
- 1) The feminism portrayed in the popular press is usually the second wave, especially when it is caricatured as a man-hating philosophy.
 - 2) It included the writings of Simone de Beauvoir and Kate Millett, who examined a female “self” constructed by male authors.
 - 3) It endeavored to mystify the dominant image of the happy American suburban housewife and mother.
 - 4) It began almost after the Second World War and was an attempt to defy prewar patriarchy.
- 121- **Which of the following is NOT correct about Martin Heidegger’s philosophy?**
- 1) What characterizes human being is its “thrownness” into the world or “facticity”.
 - 2) “Dread” compels us to grapple with daily concerns, urging us to seek meaning and structure in life.
 - 3) Human beings have lost themselves in the distractions of worldly aims, as well as in technology and gadgetry.
 - 4) Existential time is unique to a particular person’s consciousness; a person’s life is most fundamentally constituted by time.
- 122- **“Critical concept: definition” match correctly in all the following EXCEPT**
- 1) **symbolic violence**: a term coined by Pierre Bourdieu to describe the process whereby the dominant social class imposes their ideology on the dominated classes
 - 2) **bricolage**: The French word for ‘tinkering,’ ‘making do.’ A term used by Claude Lévi-Strauss to compare Western science and ‘primitive’ mythic thought
 - 3) **contact zone**: Mary Louise Pratt’s term for social places and spaces where disparate cultures meet and affect each other
 - 4) **contrapuntal reading**: Hans Robert Jauss’s term for a strategy of reading in a pluralistic critical practice

- 123- Which of the following statements about spatial criticism in the 20th century is NOT correct?**
- 1) Henri Lefebvre's major work of spatial theorization, *The Production of Space* (1974), has dramatically impacted work in a wide range of disciplines, from urbanism, architecture, and social theory to literary and cultural studies.
 - 2) As Soja emphasizes, Western modernity is thus to be reconceived as both a historical and a geographical-spatial project, a continuous dissolution and reorganization of the environments, including our bodies, that we all inhabit.
 - 3) In recent years, more and more attention has been given to how diverse subaltern publics can 'divert and reappropriate' dominated spaces. For example, such lessons are to be found in Gaston Bachelard's celebrated evocation, in *The Practice of Everyday Life*, of a transgressive 'walking in the city' effected by the people who inhabit it.
 - 4) What links the diverse projects of spatial studies of various thinkers such as Heidegger, Bachelard, Mikhail Bakhtin, and Walter Benjamin in the 20th century is a common challenge to the Enlightenment and the Cartesian notion of space as an objective homogeneous extension (*res extensa*), distinct from the subject (*res cogitans*), and the Kantian concept of space as an empty container in which human activities unfold.
- 124- Which of the following statements about Deleuze is NOT correct?**
- 1) For Deleuze, an 'essence' is not some isolated and unchanging thing, such as the supposed essence of 'human nature'. An 'essence' is a capacity, tendency, or power to become. The essence of philosophy does not lie 'in,' say, the works of Plato; it is a power to produce philosophical problems, both in the actual texts of the past and the potential texts of the future. Philosophy and literature differ in their powers or potentials.
 - 2) Far from *deciding* what a text means from some separate point of view of judgment and far from making sense of a text, Deleuze's practice of reading was one of encounter: what does this text do to thinking? And sense, for Deleuze, is not something a reading uncovers.
 - 3) According to Deleuze, western thought has often failed to ask proper transcendental questions. We usually begin from some transcendent term, or 'plane of transcendence'; we presuppose the mind of man, or matter, or the perceiving human eye.
 - 4) Concepts, Deleuze argues, must be discussed as isolated entities. A concept allows thought to move around and create, but it can do so only by producing a 'plane': a series of atomized moves that will enable us to ask meaningful questions.

- 125- “**Term: definition**” match correctly in all the following EXCEPT
- 1) **Anxiety of Influence:** Coined by Harold Bloom, explores poetic indebtedness. Bloom’s theory delves into how later poets grapple with the influence of major poets, termed ‘strong.’ He contends that poets often ‘misread’ their predecessors, creating their own ‘strong’ poetry. According to Bloom, this process involves unavoidable ‘anxieties of indebtedness.’
 - 2) **Mimicry:** As per Homi Bhabha, is viewed positively—a way for the colonizer to share culture and foster understanding. The Anglicization of Indians and Africans during British colonial rule is seen as a benevolent attempt to bridge cultural gaps, emphasizing harmony over control.
 - 3) **Subaltern:** A term taken from the work of Antonio Gramsci and used initially to define proletarian and other working-class groups, the subaltern is employed in postcolonial studies after Gayatri Spivak to address dominated and marginalized groups.
 - 4) **Suture:** A term in Lacanian psychoanalysis describing the moment that a given subject enters into language; hence, the suture denotes the linguistic gap that the subject subsumes within a given language.
- 126- **Which of the following is NOT correct about New Historicism?**
- 1) New historicists learned from deconstruction to study history with close attention to a multiplicity of meanings, contradictions, and omissions to question the ‘facts’ of history – and the ‘facts’ of literature.
 - 2) New historicists derived from Clifford Geertz the importance of immersion in a culture to understand its “deep” ways, as opposed to distant observation.
 - 3) It concerns extraliterary matters – letters, diaries, films, paintings, medical treatises – looking to reveal opposing historical tensions in a text.
 - 4) New historicism acknowledges the periodization of history and avoids ordering it only through the interplay of forms of power.
- 127- **The following excerpt is from**
“The aim, in short, should be to orientate ourselves towards placing Kenya, East Africa, and then Africa in the center. All other things are to be considered in their relevance to our situation, and their contribution towards understanding ourselves.”
- 1) Ngugi wa Thiong’o’s “On the Abolition of the English Department” (1968)
 - 2) Paula Gunn Allen’s “Kochinnenako in Academe” (1986)
 - 3) Gerald Graff’s “Taking Cover in Coverage” (1986)
 - 4) Chinua Achebe’s “The Novelist as Teacher” (1965)
- 128- **Gayatri Chakravorty Spivak’s concept of “strategic essentialism”**
- 1) reveals her deconstructionist feminist emphasis on the fallacy of essentialism—that is, the view that there is an essential human nature, or a set of defining human features, which is innate and universal
 - 2) opposes “difference feminism,” which stresses alliances among women across their differences, and hopes to replace the differences with solidarity based on shared essential qualities and experiences
 - 3) shows flexibility in her thinking by temporarily putting aside the critique of essentialism as a negative practice and turning towards essentialism as a means to resist essentialism
 - 4) argues the impossibility of the discursive formation of an “essential unity” among heterogeneous groups as a basis for strategic political action

The Long Story (Questions 129 - 142)

- 129- “The novel: genre” match EXCEPT in
- 1) Paul Auster’s *City of Glass*: Magical Realism
 - 2) William Gibson’s *Neuromancer*: Cyberpunk
 - 3) George Orwell’s *Animal Farm*: roman-à-clef
 - 4) John Fowles’s *The French Lieutenant’s Woman*: Historiographic Metafiction
- 130- “Character: the novel” match in all the following EXCEPT
- 1) Jake Barnes: *A Farewell to Arms*
 - 2) Elizabeth Bennet: *Pride and Prejudice*
 - 3) Jason Compson: *The Sound and the Fury*
 - 4) Antoinette Cosway: *The Wide Sargasso Sea*
- 131- All of the following novels are about the First and the Second World Wars EXCEPT
- 1) Norman Mailer’s *The Naked and the Dead*
 - 2) Rebecca West’s *The Return of the Soldier*
 - 3) Graham Greene’s *The Quiet American*
 - 4) Joseph Heller’s *Catch 22*
- 132- Jane Austen’s *Northanger Abbey* is a/an
- | | |
|--------------------------------|----------------------------|
| 1) critique of Romantic poetry | 2) parody of gothic novels |
| 3) autobiographical novel | 4) bildungsroman |
- 133- Identify the novelist:
 “A different perspective on Native American-white relations can be found in the author’s *Hope Leslie*, published in 1827. The author’s novel is set during the Pequot wars. In this novel, we find a portrayal of cultures in conflict overlaid by a conventional romantic plot with elements of the Pocahontas legend.”
- | | |
|-----------------------------|--------------------------|
| 1) Catharine Maria Sedgwick | 2) James Fenimore Cooper |
| 3) Hannah Webster Foster | 4) Washington Irving |
- 134- The complete title of the novel *Frankenstein* is *Frankenstein; or,*
- | | |
|------------------------------|---------------------------------|
| 1) <i>The Monster</i> | 2) <i>The Devil’s Walk</i> |
| 3) <i>The Evil Scientist</i> | 4) <i>The Modern Prometheus</i> |
- 135- “The novelist: novels” match EXCEPT in
- 1) Maxine Hong Kingston: *The Woman Warrior, China Men, Tripmaster Monkey*
 - 2) Mohsin Hamid: *Exit West, The Reluctant Fundamentalist, The Last White Man*
 - 3) Louise Erdrich: *Love Medicine, Tracks, The Beat Queen*
 - 4) Alice Walker: *The Color Purple, Tar Baby, Jazz*
- 136- Which statement about *Waiting for the Barbarians* is NOT correct?
- 1) The Magistrate begins to question the legitimacy of colonialism and personally nurses a barbarian girl maimed by the Third Bureau’s torturers.
 - 2) The Magistrate, anticipating a barbarian attack in retaliation for colonial suppression, encourages the townspeople to evacuate promptly.
 - 3) The story is narrated in the first person by the unnamed Magistrate of a settlement on the territorial frontier of “The Empire.”
 - 4) The novel is written by the South African Writer J. M. Coetzee and was first published in 1980.

137- Which statement about *A Passage to India* is NOT correct?

- 1) In the trial, Adela asserts her certainty about who had attacked her. Also influenced by the pressure to persist in her accusation, she upholds the charge.
- 2) Even when Dr. Aziz and Mr. Fielding reunite years later, Dr. Aziz remains drawn to Fielding. However, he recognizes that true friendship is contingent on India gaining independence from British rule.
- 3) It is a novel penned by the English author E. M. Forster in 1924, set against the backdrop of the British Raj in the 1920s.
- 4) The storyline unfolds as Adela believes that Dr. Aziz assaulted her during a visit to the Marabar Caves.

138- How does the character of Bertha Mason in Charlotte Brontë's *Jane Eyre* contribute to the novel's exploration of gender roles and societal expectations?

- 1) Bertha's rebelliousness serves as a moral compass for the protagonist, Jane.
- 2) The novel reinforces traditional gender norms through Bertha's character.
- 3) The novel challenges the confinement of women to narrow societal roles.
- 4) Bertha represents the ideal Victorian woman.

139- Which statement is NOT correct about Kazuo Ishiguro?

- 1) The five novels by Ishiguro published in the period up to 2000 are intricately crafted, psychologically absorbing, hauntingly evocative works that betray the author's grounding not only in the realist European novelistic tradition but also in the discourse of modern psychology.
- 2) Ishiguro's *Last Orders* centers on a world-famous English pianist, Ryder, who visits an unidentified central European city for a few days to give a recital and help the city resolve its nagging artistic and identity crises.
- 3) All of Ishiguro's first-person protagonists — Etsuko in *A Pale View of Hills*, Ono in *An Artist of the Floating World*, Stevens in *The Remains of the Day*, Ryder in *The Unconsoled*, and Christopher Banks in *When We Were Orphans* — tell stories that mask or distort rather than uncover the most revealing implications of their tales.
- 4) Ishiguro's *The Remains of the Day* is a profound novelistic exploration of narrator and narrative repression and emotional fascism. Like all of Ishiguro's protagonists, Stevens the butler, despite his apparent eagerness to divulge his life story, works hard to conceal the alarming significance and troubling consequences of his past.

140- Which of the following statements is NOT correct?

- 1) James Joyce reaches the apex of skill and complexity in techniques such as stream of consciousness and interior monologue in *A Portrait of the Artist as a Young Man*.
- 2) *Dubliners*, initially published in 1914, is a collection of short stories providing a naturalistic portrayal of life in and around the Irish middle class in the early 20th century.
- 3) James Joyce invented a distinctive polyglot language, known as idiosglossia, exclusively for the composition of *Finnegans Wake*. This linguistic creation comprises composite words drawn from dozens of global languages.
- 4) In *Ulysses*, James Joyce crafted several episodes, each mirroring an hour of the day with a unique literary style. Each chapter is meticulously structured to reference an episode from Homer's *Odyssey*, accompanied by a specific color, art or science, and bodily organ.

141- Which statement can NOT be correct about modernists and modernism?

- 1) Melville, who achieved significant fame in the 19th century for his literary accomplishments, faced severe criticism and condemnation from modernists due to his celebration of the expanding nation-state.
- 2) D. H. Lawrence believed that the novel's emerging reality should embody the genuine experiences of the body — encompassing its visceral, sexual, and sometimes even violent feelings and encounters.
- 3) Modernist critics, such as Ford Madox Ford, believed that novels prior to the modernist era tended to arrange events in chronological order, creating an artificial and predictable narrative structure.
- 4) Willa Cather wrote an essay titled “The Novel Démeublé,” in which she asserted that “the novel, for a long while, has been overfurnished,” laden with an excess of details that obstructed its clarity of vision.

142- All the following statements are correct EXCEPT that

- 1) the shape of Jean Toomer's *Cane* is as “tortured” as the form of life it evokes. So the shape itself is significant — meaningful precisely because it seems incoherent, a broken mirror only better able to reflect a shattered culture.
- 2) Tom Willards' journey in Sherwood Anderson's *Winesburg, Ohio* mirrors the typical *bildungsroman*. The protagonist matures into contentment, growing more certain that he must overcome his alienation and reconnect with the community.
- 3) Ford Madox Ford's *The Good Soldier* may be about adultery, betrayal, and hypocrisy, but more fundamentally, it is about reality and how we make it up. It is about how truths vary, depending upon different perspectives, and how life is essentially the process of testing them.
- 4) Dorothy Richardson's *Pilgrimage*, a multi-volume exploration of a woman's evolving mind, pioneered a new style to convey the intricacies of female thoughts. Richardson aimed to create a feminine alternative to prevailing masculine realism, allowing the “form of contemplated reality” its own expression.

Seventeenth and Eighteenth Centuries Literature (Questions 143-151)**143- “Play: setting” match in all the following EXCEPT**

- | | |
|--------------------|----------------------------|
| 1) Othello: Cyprus | 2) Macbeth: Ireland |
| 3) Hamlet: Denmark | 4) Romeo and Juliet: Italy |

144- Which of the following does NOT open a poem by John Donne?

- 1) “As virtuous men pass mildly away, / And whisper to their souls to go,”
- 2) “Mark but this flea, and mark in this, / How little that which thou deniest me is;”
- 3) “Let me not to the marriage of true minds, / Admit impediments. Love is not love”
- 4) “For God's sake hold your tongue, and let me love, / Or chide my palsy, or my gout,”

145- is one of the earliest works of science fiction. This novel tells the story of a Spanish adventurer who travels to the moon using a machine powered by geese.

- 1) *The Moon and Sixpence* by W. Somerset Maugham
- 2) *From the Earth to the Moon* by Jules Verne
- 3) *The Man in the Moone* by Francis Godwin
- 4) *The Moonstone* by Wilkie Collins

- 146- Which statement does NOT complete the following sentence correctly?
The Compleat Angler by Izaak Walton, first published in 1653,
- 1) is a celebration of the virtues of pastoral life and contentment
 - 2) promotes the idea that nature is an inexhaustible resource to serve human needs
 - 3) contains philosophical musings about nature and discusses the seasons
 - 4) is a fishing guide offering practical advice on the practice
- 147- Which statement is NOT correct about *Absalom and Achitophel* (1681) by John Dryden?
- 1) It is a political allegory that uses biblical figures to represent contemporary figures.
 - 2) It is a satirical poem that addresses the Monmouth Rebellion and the Exclusion Crisis.
 - 3) It is notable for its portrayal of historical figures, with King David representing King Charles II.
 - 4) It is a bombastic poem celebrating the triumphant rule of Absalom, who brings prosperity and unity to the kingdom.
- 148- Which statement best describes *Paradise Regained* by John Milton?
- 1) It showcases Milton's mastery of metrical elegy and his poetic craftsmanship. The rich and evocative language demonstrates Milton's ability to convey complex ideas eloquently.
 - 2) The poem explores theological themes, particularly the nature of temptation, virtue, and the significance of Christ's resistance to worldly allurements in a style deviating from the solemn tone of *Paradise Lost*.
 - 3) The bulk of the epic takes place in a desert wilderness, where Jesus rejects modes of public action as satanic temptation. Despite Jesus's triumph, the poem famously ends with him returning to his mother's house privately and unnoticed.
 - 4) It strongly emphasizes Christ's intellectual and moral strength by using allegorical elements embedded in its poetic form as a sonnet sequence. It conveys spiritual and moral lessons by portraying him as a heroic figure who triumphs over the temptations.
- 149- Which work of literature does the following text describe?
"It is a long narrative poem that consists of six books. It was published in 1785 and is considered one of the major works of 18th-century English literature. It explores the simplicity and pleasures of domestic life, emphasizing the joys of home and family. The poem begins with contemplating a sofa, using it as a starting point for the writer's reflections. The poet then discusses a wide range of topics, meandering through his thoughts in a conversational and personal manner."
- 1) Oliver Goldsmith's *The Deserted Village*
 - 2) Alexander Pope's *The Messiah*
 - 3) James Thomson's *The Seasons*
 - 4) William Cowper's *The Task*

- 150- “Title: description” match correctly EXCEPT in
- 1) *Venice Preserv'd* by Thomas Otway: Set against the backdrop of a political conspiracy in Venice, this tragedy explores the themes of betrayal and revenge. The character Jaffier seeks revenge for perceived injustices.
 - 2) *The Changeling* by Thomas Middleton and William Rowley: This play features a subplot involving revenge, where De Flores manipulates and seeks revenge against the object of his desire, Beatrice-Joanna.
 - 3) *The Mourning Bride* by William Congreve: While primarily a tragedy of love, this play includes elements of revenge involving the character Zara, who seeks vengeance against her husband for perceived betrayals.
 - 4) *The Revenger's Tragedy* by George Etherege: This Jacobean revenge tragedy is known for its dark humor and cynicism. The protagonist, Ferdinand, seeks revenge for the murder of his wife and children.
- 151- Which critical view does NOT correctly reflect Francis Bacon's *Advancement of Learning* and its reception?
- 1) Some critics praise Bacon for introducing a new method of scientific inquiry. Bacon advocated a systematic and empirical approach to acquiring knowledge through observation, experimentation, and inductive reasoning.
 - 2) Bacon's literary style, characterized by aphorisms and concise expression, is often admired for its clarity and rhetorical force. Yet, to some, his difficult or overly ornate writing style might obscure the clarity of his ideas for modern readers.
 - 3) Bacon's identification and critique of the “Idols of the Mind” are seen as a valuable contribution. He categorized various biases and errors in human thinking that could impede the pursuit of knowledge, urging a critical examination of preconceptions and biases.
 - 4) Bacon's utilitarian perspective on knowledge, focusing on improving human life and alleviating suffering, has been widely criticized and abandoned. Critics argue that his overly pragmatic approach to scientific inquiry neglects the inherent value of knowledge for its own sake.

Contemporary Poetry (Questions 152-160)

- 152- Which of the following poems best represents the ideas of the Harlem Renaissance?
- 1) “Chicago” by Carl Sandburg
 - 2) “Heritage” by Countee Cullen
 - 3) “A Far Cry from Africa” by Derek Walcott
 - 4) “Emperor Ice Cream” by Wallace Stevens
- 153- Which one is a great patriotic poem by Robert Frost?
- 1) “The Gift Outright”
 - 2) “Mending Wall”
 - 3) “Directive”
 - 4) “Birches”
- 154- “Movements/groups: poets” match correctly in all the following EXCEPT
- 1) The Lake Poets: William Wordsworth, Samuel Taylor Coleridge, Robert Southey
 - 2) The Beat Generation: Jack Kerouac, Allen Ginsberg, William S. Burroughs
 - 3) Confessional Poetry: Kingsley Amis, Philip Larkin, Donald Alfred Davie
 - 4) Imagists: T. E. Hume, F. S. Flint, Hilda Doolittle

155- Taking a clue from the content, which poet has composed the following lines?

Man looking into the sea,
taking the view from those who have as much right to it as you have to it yourself,
it is human nature to stand in the middle of a thing,
but you cannot stand in the middle of this;

- | | |
|---------------------|-------------------|
| 1) Hart Crane | 2) Ted Hughes |
| 3) Elizabeth Bishop | 4) Marianne Moore |

156- Which poetry excerpt can best be identified as jazz?

- 1) "For you will come, / you will yet haunt men in ships, / you will trail across the fringe of strait / and circle the jagged rocks."
- 2) "The stroke begins again— / regularly automatic / contrapuntal to the flogging / like the beat of famous lines"
- 3) "That time resumes, / One thinks of all the hands / That are raising dingy shades / In a thousand furnished rooms."
- 4) "Good morning, daddy! / Ain't you heard / The boogie-woogie rumble / Of a dream deferred"

157- Which statement does NOT correctly describe Allen Ginsberg's poetry in 'Howl'?

- 1) Ginsberg's 'Howl' combines experimental language with a traditional poetic form to produce an amalgamation of conservative aesthetics and avant-garde expressions, seamlessly blending conformity with rebellion within the confines of a structured sonnet.
- 2) The poem celebrates those who defy societal norms and embrace individuality. Ginsberg portrays the marginalized, the disenfranchised, and those living on the fringes of society with empathy and understanding.
- 3) The poem reflects Ginsberg's struggles with mental health, as well as the experiences of those he observed. It captures a sense of alienation and despair felt by individuals who did not fit into the mainstream culture.
- 4) Ginsberg criticizes the dehumanizing impact of capitalism and consumer culture, lamenting what he perceives as the loss of genuine human connections in the pursuit of material success.

158- Which statement is correct?

- 1) "Paterson" is an epic poem by William Carlos Williams that explores various themes, including history, place, and the poet's role.
- 2) "A Poetics" is Charles Bernstein's collection of poetry in which he reflects on the nature of life, death, and divinity in contemporary society.
- 3) "Self-Portrait in a Convex Mirror" is a collection of poetry by Amiri Baraka known for its intricate language, self-reflexivity, and engagement with art.
- 4) "The Bridge" is Hart Crane's epic poem dedicated to and composed in emulation of Walt Whitman to capture the complexity of American cultural identity.

159- Which statement about Ezra Pound's *The Spirit of Romance* is NOT correct?

- 1) In this work, he compares Shakespeare's rhetorical play with Dante's rich images and finds the latter the superior of the two.
- 2) In this work, he expresses his dismissive attitude to Renaissance poetry and condemns its rhetorical play.
- 3) He praises Latin poets for how their outer style matches the inner spirit of their poetry.
- 4) He establishes his later opposition to symbolist-oriented techniques in poetry in this work.

160- Which of the following does NOT include chiasmus?

- 1) Woman, a pleasing but a short-lived flow'r, / Too soft for business and too weak for pow'r:
/ A wife in bondage, or neglected maid; / Despised, if ugly; if she's fair, betrayed.
- 2) The old husband sleeps by his wife and the young husband sleeps by his wife; / And
these tend inward to me, and I tend outward to them, / And such as it is to be of these
more or less I am,
- 3) Wilt thou thy self / Abolish thy Creation, and unmake, / For him, what for thy glorie
thou hast made? / So should thy goodness and thy greatness both / Be questiond and
blasphem'd without defence
- 4) Most glorious, in him all his Father shon / Substantially express'd, and in his
face / Divine compassion visibly appeerd, / Love without end, and without measure
Grace, / Which uttering thus he to his Father spake.

روش تحقیق در ترجمه - نظریه‌های ترجمه - نقد ترجمه - فرهنگ و جامعه‌شناسی در ترجمه:

Research Methodology in Translation (Questions 161 - 175)
161- Network analysis falls under the broad category of

- | | |
|---------------------------------|-------------------------|
| 1) ethnography of communication | 2) bibliometric studies |
| 3) experimental research | 4) action research |

162- The Hawthorne effect is an example of threat to the validity of a research.

- | | | | |
|---------------|-------------|----------------|-------------|
| 1) maturation | 2) external | 3) measurement | 4) internal |
|---------------|-------------|----------------|-------------|

163- For data that can be quantified, the level of measurement where a concept can be ranked, but where it is not possible to measure differences between each label, is called scale data.

- | | |
|-------------|----------------|
| 1) ordinal | 2) categorical |
| 3) interval | 4) ratio |

164- Which of the following statements is NOT correct about the Nexus model proposed by Koskinen (2010)?

- 1) It tries to identify the sequence of events and conditions.
- 2) The model does not focus on making correlations.
- 3) The model is suitable for case studies.
- 4) It focuses on causal effects.

165- Based on the model of textual analysis, there are four types of narrative that construct our world, namely,

- 1) social, systemic, contemporary, and applied
- 2) historical, theoretical, self, and official
- 3) disciplinary, public, personal, and metanarratives
- 4) descriptive, analytical, interpretive, and explorative

166- The interviews maintain the focus on the central research question but will develop conversationally.

- | | |
|------------------|--------------------|
| 1) unstructured | 2) semi-structured |
| 3) developmental | 4) formalized |

- 167- **The fundamental challenge generally associated with experimental research designs is the issue of validity.**
- 1) statistical conclusion
 - 2) criterion-related
 - 3) ecological
 - 4) construct
- 168- **The ontology of maintains that the social phenomena that make up our social world have an existence of their own, apart from and independent of the social actors who are involved.**
- 1) constructivism
 - 2) objectivism
 - 3) interpretivism
 - 4) realism
- 169- **Which of the following is NOT an important advantage of experimental studies as opposed to naturalistic studies?**
- 1) Replicability
 - 2) High generalizability
 - 3) High observability
 - 4) Elimination of confounding effects
- 170- **The hypothesis: "translation is best conceived as a kind of artistic production rather than as a faithful reproduction of a source text" is an example of hypothesis.**
- 1) predictive
 - 2) explanatory
 - 3) descriptive
 - 4) interpretive
- 171- **The four most common types of probability sampling are,,, and Sampling.**
- 1) random, systematic, stratified, cluster
 - 2) systematic, snowball, cluster, random
 - 3) network, purposive, stratified, snowball
 - 4) network, stratified, cluster, layered
- 172- **Which of the following statements is NOT correct, regarding Mann-Whitney U-test?**
- 1) The procedure for calculating the Mann-Whitney test involves the ranks of the observations, rather than the raw data.
 - 2) It can have greater statistical power than parametric methods in the situation of non-normality.
 - 3) The test is appropriate in the case of unequal variances.
 - 4) It is used with relatively small samples.
- 173- **The advantages of include maximizing and minimizing**
- 1) probability sampling, generalizability, sampling error
 - 2) probability sampling, washback effect, Hawthorne effect
 - 3) non-probability sampling, generalizability, sampling error
 - 4) non-probability sampling, washback effect, Hawthorne effect
- 174- **At a minimum, statistics require both a measure of central tendency and a measure of**
- 1) analytic, clustering
 - 2) analytic, variability
 - 3) descriptive, clustering
 - 4) descriptive, variability

- 175- In contrast to other research approaches, shift(s) the locus of control from "objective" professional or academic researchers to individuals who traditionally have been the subjects of research.
- | | |
|--------------------------------|--------------------------|
| 1) interviews and focus groups | 2) survey-based research |
| 3) action research | 4) case studies |

Translation Theories (Questions 176 - 190)

- 176- The term refers to the act of recruiting an undefined, large group of translators to take on a specific translation task which would usually be assigned to in-house translators.
- | | | | |
|---------------|------------------|------------------|---------------------|
| 1) entrusting | 2) commissioning | 3) crowdsourcing | 4) mass customizing |
|---------------|------------------|------------------|---------------------|
- 177- A stage of translation theory which started around 1970 and focused on the intention of a text and its essential message, rather than the language of the source text, is called the stage.
- | | | | |
|----------------|------------------|------------------|--------------------|
| 1) descriptive | 2) functionalist | 3) communicative | 4) text-linguistic |
|----------------|------------------|------------------|--------------------|
- 178- One component of Translation Environment Tool (TEtT) is the, which searches a (bi)text for all occurrences of a user-specified character string and displays these in context.
- | | |
|-----------------------------|------------------------------|
| 1) concordancer | 2) term extractor |
| 3) document analysis module | 4) project management module |
- 179- Considering translation as a form of paratext runs the risk of
- 1) challenging the very existence of the concept of original
 - 2) undermining the conventional hierarchy between ST and TT
 - 3) reducing translation to a mere commentary on the original
 - 4) overemphasizing marginal translation cases in translation studies
- 180- According to Pym, the ethical choices made by translators in intercultural spaces extend to
- | | |
|-----------------------------|--------------------------|
| 1) intralingual translation | 2) language facilitation |
| 3) cultural negotiation | 4) linguistic mediation |
- 181- What are the four strategic functions used to categorize and understand the relation between translation and politics?
- 1) Assimilation, coercion, appropriation, and discrimination
 - 2) Politicization, liberation, (dis)simulation, and representation
 - 3) Democratization, civic consent, resistance, and hegemony
 - 4) Resistance, coercion, dissimulation, legitimization
- 182- According to Quine, translation refers to the translation of the language of a hitherto untouched people, where the translator has neither linguistic similarities nor common culture to rely on, and so is forced to decipher an alien language from first principles.
- | | |
|-------------|-----------------|
| 1) radical | 2) cultural |
| 3) exegetic | 4) ethnographic |

- 183- Which item is NOT a consequence of the cultural turn in translation studies?
 1) Revisionist theories and approaches
 2) Philosophical denial of the role of theory
 3) Diversification of the studied phenomenon
 4) Focus on agents of translation and interpreting
- 184- According to Toury (1985), translation can contribute to the of minority languages while potentially leading to
 1) development, asymmetrical power relations
 2) normalization, the effacement of their specificity
 3) domination, the displacement of majority languages
 4) preservation, an undesired amount of interference
- 185- According to Vermeer, the translator should create a text that conforms to the standard of coherence, which means that the audience of the text should be able to understand it and the text should be acceptable to them.
 1) metatextual
 2) intertextual
 3) extratextual
 4) intratextual
- 186- In her model, van Leuven-Zwart attempted to map semantic shifts logged at the microlevel of the source and target texts onto the macrolevel of structure.
 1) social
 2) cultural
 3) narrative
 4) discoursal
- 187- “There can be no essential meaning or concept that could be clearly separated from its linguistic fabric and, therefore, be fully transportable elsewhere.” This sentence best describes the perspective in translation studies.
 1) realist
 2) relativist
 3) essentialist
 4) positivist
- 188- According to Koller, equivalence concerns aesthetic features of the text, including wordplays and the individual stylistic features of the ST.
 1) formal
 2) dynamic
 3) connotative
 4) pragmatic
- 189- According to Reiss, a basically expressive text such as a poem or a play calls for a/an method of translation, where the translator associates him/herself with the originator of the text.
 1) plain prose
 2) identifying
 3) adaptive
 4) suppletary
- 190- Nida uses the term translation to refer to a type of translation by means of which the form and content of the source language text are recreated in the target text as closely as possible and in such a way that they are comprehensible to the target text reader.
 1) thick
 2) oblique
 3) gloss
 4) semantic

Translation Criticism (Questions 191 - 205)
--

- 191- The following factors can impact the of a test:
(1) Variation in test administration settings, (2) variation in test rubrics, (3) variations in test input, and (4) variation in expected response.**
- | | |
|---------------------|-----------------------|
| 1) reliability | 2) authenticity |
| 3) content validity | 4) construct validity |
- 192- Given the aim of aptitude tests, validity becomes their most important feature.**
- | | |
|--------------|---------------|
| 1) criterion | 2) content |
| 3) construct | 4) predictive |
- 193- The Calibration of Dichotomous Items (CDI) is a method for evaluating translation competence in which**
- 1) assessment is directed towards the process rather than the product of translation
 - 2) the process and product of translation are both taken into consideration
 - 3) assessment is carried out on certain parts of the translated text
 - 4) the translated text is treated as a whole
- 194- As a feature of translation competence, demands translators to be always on the lookout for new ways of saying something, not just relying on their dictionaries; they must always feel the pulse of language and seek advice from experts and continually research their texts.**
- | | |
|------------------|-------------------|
| 1) heterogeneity | 2) situationality |
| 3) approximation | 4) open-endedness |
- 195- In the House model of translation quality assessment, refers to a structural parallelism that occurs when two or more sentences in a text cohere because those sentences are isomorphic at the surface level.**
- | | |
|--------------------|-------------------------|
| 1) theme dynamics | 2) iconic linkage |
| 3) clausal linkage | 4) cataphoric reference |
- 196- Statements like “the translation doesn’t capture the spirit of the original”, “the tone of the original is somehow lost in the translation”, and “the translation is as good as or even better than the original” are typical of the views towards translation quality assessment.**
- | | |
|------------------|------------------|
| 1) mentalist | 2) behavioristic |
| 3) functionalist | 4) linguistic |
- 197- In Crystal and Davy’s scheme of situational dimensions, refers to the text producer’s professional activity, the topic of the text, and the area of operation of the language activity, as well as the details of text production.**
- | | |
|-----------------------------|------------------|
| 1) social role relationship | 2) participation |
| 3) province | 4) medium |

- 198- In his approach to translation quality assessment, van den Broeck distinguishes shifts, i.e., those determined by the rules of the target linguistic and cultural system, and shifts, i.e., those emanating from the translator's decisions – a classification later taken up by Pym's division of equivalence into and equivalence.
- 1) optional, obligatory, directional, natural
 - 2) obligatory, optional, directional, natural
 - 3) optional, obligatory, natural, directional
 - 4) obligatory, optional, natural, directional
- 199- Behavioristic views can be classified under the more general category of approaches to translation quality assessment.
- 1) philosophical
 - 2) psycho-social
 - 3) response-based
 - 4) linguistically-oriented
- 200- New Criticism, which resorted to close reading of the literary text and carefully examined its formal elements, was a form of criticism common from the 1940s through the 1960s.
- 1) intrinsic
 - 2) subjective
 - 3) extrinsic
 - 4) biographical
- 201- According to Lacanian psychoanalysis, the acquisition of language initiates the, in which the child perceives itself as a separate and gendered being.
- 1) mirror stage
 - 2) symbolic order
 - 3) imaginary order
 - 4) castration complex
- 202- According to Rosenblatt's transactional reader-response theory, every text acts as a stimulus to which we respond in our personal way; it simultaneously acts as a that we can use to correct our interpretation and guides our self-corrective process.
- 1) lens
 - 2) touchstone
 - 3) yardstick
 - 4) blueprint
- 203- The act of relating to objects or persons in terms of their exchange value or sign-exchange value, according to Marxist critics, is called
- 1) commodification
 - 2) alienation
 - 3) materialism
 - 4) capitalism
- 204- The psychological programming by which a racist society indoctrinates people of color to believe in white superiority leads to a type of racism which is called racism.
- 1) everyday
 - 2) internalized
 - 3) unconscious
 - 4) institutionalized
- 205- According to Frye's classification of the structure of literary genres, the mythos of spring is associated with, which involves a movement from the cold real world to a happier, kinder, gentler fictional space.
- 1) satire
 - 2) irony
 - 3) romance
 - 4) comedy

Culture and Sociology in Translation (Questions 206 - 215)

- 206- Which item refers to the productive aspect of translation norms?**
- 1) Dichotomizing the compliant/non-compliant strategies
 - 2) Facilitating translators, decision-making processes
 - 3) Enhancing the flexibility of censorship mechanisms
 - 4) Prescribing the appropriate translation strategy
- 207- In the context of intercultural interaction through translation, how do mutualism and commensalism compare?**
- 1) Mutualism implies that both cultures benefit, whereas commensalism primarily benefits one culture.
 - 2) Commensalism and mutualism are terms used interchangeably, having no significant difference.
 - 3) Mutualism refers to a one-sided benefit for the source culture, unlike commensalism.
 - 4) Commensalism emphasizes a stronger cultural exchange compared to mutualism.
- 208- Bernard Lahir criticizes Bourdieu's concept of habitus for its**
- 1) differentiated nature
 - 2) universalist stance
 - 3) pluralist logic
 - 4) collectivism
- 209- As suggested by the application of to translation studies, foreignization can be seen as a disruption of the prevailing socially-ascribed role of translation.**
- 1) Schutz's sociological phenomenology
 - 2) Bourdieu's theory of social fields
 - 3) Weber's interpretive sociology
 - 4) Goffman's dramaturgical approach
- 210- Which metaphor best describes translation as conceptualized according to the Parsonian theory of homeostasis?**
- 1) Translation as metempsychosis
 - 2) Translation as role-playing
 - 3) Translation as bridge-builder
 - 4) Translation as social action
- 211- Conceptualized within Luhmann's Social Systems Theory, translation shows its potential at the stage of in the process of sociocultural evolution.**
- 1) progressive, stabilization
 - 2) innovative, variation
 - 3) conservative, mediation
 - 4) revolutionizing, selection
- 212- What does Michèle Ollivier suggest about the nature of occupational prestige?**
- 1) Occupational prestige is an absolute and objective notion.
 - 2) Occupational prestige is primarily determined by educational background and income.
 - 3) Occupational prestige scales reflect a normative evaluation of the worth of occupations.
 - 4) Occupational prestige is multifaceted and context-dependent.

- 213- What distinguishes interactional power from institutional power in interpreting?**
- 1) Interactional power pertains to the interpreter's ability to shape communication dynamics, while institutional power is related to governments and authorities.
 - 2) Interactional power is solely determined by the interpreter's language proficiency, while institutional power comes from cultural proficiency.
 - 3) Interactional power is about controlling legal settings, while institutional power is associated with medical settings.
 - 4) Interactional power is a passive element in interpreting, while institutional power is an active force in the field.
- 214- Which of the following best characterizes the motivation behind Bourdieu's and Giddens's sociological theories and their approach to reconciling structure and agency in social analysis?**
- 1) Both scholars focus on understanding the unity between social structures and agents through their emphasis on everyday practices.
 - 2) Giddens's theory primarily revolves around the idea of duality of structure, while Bourdieu's theory focuses on the notion of habitus and field.
 - 3) Bourdieu primarily focuses on the dichotomy between structure and agency, while Giddens aims to eliminate this distinction entirely.
 - 4) Bourdieu and Giddens both emphasize the separation of social structures and individual actions.
- 215- Applying to translation studies can lead to the inclusion of both human and non-human agents of translation.**
- | | |
|----------------------------------|----------------------------|
| 1) social constructivism | 2) symbolic interactionism |
| 3) Latour's Actor-Network Theory | 4) phenomenology |

کد کنترل

750

C



750C



جمهوری اسلامی ایران
وزارت علوم، تحقیقات و فناوری
سازمان سنجش آموزش کشور

«در زمینه مسائل علمی، باید دنبال قلّه بود.»
مقام معظم رهبری

عصر جمعه
۱۴۰۲/۱۲/۰۴

دفترچه شماره ۲ از ۳

آزمون ورودی دوره‌های دکتری (نیمه‌متمرکز) - سال ۱۴۰۳

استعداد تحصیلی

مدت زمان پاسخگویی: ۵۰ دقیقه

تعداد سؤال: ۲۵

عنوان مواد امتحانی، تعداد و شماره سؤال‌ها

ردیف	مواد امتحانی	تعداد سؤال	از شماره	تا شماره
۱	استعداد تحصیلی	۲۵	۱	۲۵

تذکر: داوطلبان گرامی حتماً در بخش چهارم (صفحه ۱۳)، موارد مندرج در کادر توجه مهم را مطالعه نمایند.

این آزمون، نمره منفی دارد.

استفاده از ماشین حساب مجاز نیست.

* داوطلب گرامی، عدم درج مشخصات و امضا در مندرجات جدول زیر، به منزله عدم حضور شما در جلسه آزمون است.

اینجانب با شماره داوطلبی با آگاهی کامل، یکسان بودن شماره صندلی خود با شماره داوطلبی مندرج در بالای کارت ورود به جلسه، بالای پاسخنامه و دفترچه سؤال‌ها، نوع و کد کنترل درج شده بر روی دفترچه سؤال‌ها و پایین پاسخنامه‌ام را تأیید می‌نمایم.

امضا:

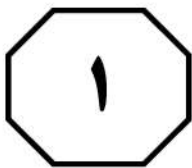

بخش اول

راهنمایی:

در این بخش، دو متن به‌طور مجزا آمده است. هر یک از متن‌ها را به‌دقت بخوانید و پاسخ سؤال‌هایی را که در زیر آن آمده است، با توجه به آنچه می‌توان از متن استنتاج یا استنباط کرد، پیدا کنید و در پاسخنامه علامت بزنید.

سطر تفکر انتقادی به منزله یک مهارت اساسی برای مشارکت عاقلانه در یک جامعه دموکراتیک شناخته می‌شود و در دنیای مُدرن امروز، یک مهارت موردنیاز است که بیشتر، به‌عنوان توانایی افراد برای به چالش کشیدن تفکراتشان درک می‌شود. این توانایی مستلزم آن است که افراد معیارهای خود را برای تجزیه و تحلیل و ارزیابی تفکراتشان گسترش دهند و به‌صورت عادی از آن معیارها و استانداردها برای گسترش کیفیت تفکراتشان استفاده کنند. تفکر انتقادی، قضاوتی هدفمند و خودگردان است که از راه تفسیر، تحلیل، ارزیابی و استنباط به نتیجه می‌رسد. همچنین آن را تفسیری می‌دانند مستند، مفهومی، روش‌شناسانه، انتقادی منطقی و ریشه‌ای در تفکر، روی آنچه قرار است درباره آن قضاوت شود، زکی، تفکر انتقادی را هنر تجزیه و تحلیل و ارزیابی تفکر همراه با بررسی برای اصلاح آن تعریف می‌کند. راسموسن، تفکر انتقادی را یکی از مهم‌ترین اصول آموزشی هر کشور می‌داند و هر جامعه‌ای برای رسیدن به رشد و شکوفایی، نیاز به افرادی دارد که دارای تفکر انتقادی بالایی باشند. آموزش تفکر انتقادی منجر به انگیزه جهت یادگیری، کسب مهارت‌های حل مسئله، تصمیم‌گیری و خلاقیت می‌شود. (۲۵)

آزبورن معتقد است مغز اساساً دارای دو جنبه است: مغز قضاوت‌کننده که تجزیه و تحلیل نموده، مقایسه و انتخاب می‌کند و مغز خلاق که مطالب را تجسم نموده، پیش‌بینی می‌کند و ایده تولید می‌کند. قضاوت قادر است قدرت تصور را در مسیر صحیح نگه دارد و قدرت تصور قادر است به تنویر قوه قضاوت کمک کند. یکی از ویژگی‌های بارز افراد خلاق، داشتن تفکر انتقادی است. الدر و پال در خصوص رابطه

(۳۵) بین تفکر انتقادی و تفکر خلاق معتقدند: «خلاقیت، فرایند ساخت و تولید و انتقاد، فرایند ارزیابی و قضاوت را رهبری خواهد کرد. یک ذهن سالم و رشدیافته، هم تولید و هم قضاوت خوبی خواهد داشت». درواقع، یک ذهن رشدیافته آنچه می‌آفریند را ارزیابی می‌کند، پس می‌توان گفت که مؤلفه انتقادی ناظر بر خلاقیت است، زیرا در زمان درگیر بودن در تولید اندیشه باکیفیت، ذهن باید به‌طور همزمان تولید، ارزیابی، داوری و نتیجه‌گیری کند. تأکید پیازه نیز بر تفکر خلاق و تفکر انتقادی، به دلیل اهمیت آنها در حل مسائل است و حل بیشتر مسائل، مستلزم هر دو نوع تفکر است. درواقع، خلاقیت فقط ارائه راه‌حل‌های مختلف برای حل مسئله نیست، بلکه ارائه راه‌حل‌های بهتر است و این، مستلزم قضاوت انتقادی است. بنابراین، جدا دانستن تفکر انتقادی و خلاقیت، اشتباه و این تفکیک، ساده‌انگاری افراطی است.

- ۱- کدام مورد زیر را می‌توان به‌درستی از پاراگراف ۱ استنباط کرد؟
- (۱) در کشورهای پیشرفته، تفکر انتقادی مهم‌ترین اصل آموزشی است.
- (۲) بیشتر مشکلات جوامع به دلیل فقدان تفکر انتقادی است.
- (۳) کیفیت بالای تفکر در افراد، به دلیل تفکر انتقادی است.
- (۴) تفکر انتقادی، قابلیت آموزش‌پذیری دارد.

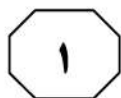
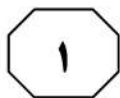

750 C



۳- کدام مورد، رابطه پاراگراف ۲ با پاراگراف ۱ را به بهترین وجه توصیف می‌کند؟
(۱) برداشته‌های جدید از موضوع مطروحه در پاراگراف ۱ را نقد و بررسی می‌کند.
(۲) با استناد به نظریات جدید، موضوع پاراگراف ۱ را تکرار و مستحکم می‌سازد.
(۳) با طرح تغییری جدید، موضوع اصلی در پاراگراف ۱ را بسط می‌دهد.
(۴) جنبه‌های عملیاتی و کاربردی نظریه مندرج در پاراگراف ۱ را تبیین می‌کند.

۲- قبول نظریات آزمون در درجه اول، مستلزم قبول کدام مورد زیر است؟
(۱) دو جنبه مغز سازه‌هایی واقعی هستند.
(۲) بین قضاوت و تصور صحیح، رابطه وجود دارد.
(۳) انسان می‌تواند با تفکر انتقادی به راه‌حل مسائل برسد.
(۴) تفاوت معنی‌داری بین مغز انسان و مغز موجودات دیگر وجود دارد.

به صفحه بعد بروید.

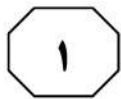
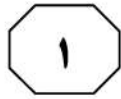
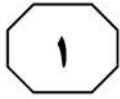

750 C



دهه ۱۹۸۰ میلادی تدوین شده بود، افزایش بی‌امان و وقفه‌ناپذیر فقر و گرسنگی و نابرابری در جهان و نیز تخریب نگران‌کننده محیط زیست و منابع طبیعی در نتیجه کاربرد تکنولوژی‌ها. [۲] توسعه پایدار منجر به ایجاد تغییرات در بنیاد هر چیزی می‌شود و همه چیز را دربر می‌گیرد، نظیر: عدالت اجتماعی، نگهداری و حفاظت میراث فرهنگی، نگهداری و حفاظت از محیط زیست، جامعه سالم، تأمین نیازهای نسل آینده، حال و بسیاری مسائل حیاتی از این دست. [۳] به‌واقع، همه این مباحث، پایه و اساس توسعه پایدار را تشکیل می‌دهد. توسعه پایدار به‌عنوان اصل بنیادین خود، فقط و فقط به مردم و تأمین نیاز و بهبود کیفیت زندگی آنان در چارچوبی ماندگار و عاقبت‌اندیشانه توجه دارد. بدین ترتیب، کوشش‌هایی برای حفظ محیط زیست شروع شد. متفکران بسیاری بر این عقیده بودند که انسان‌ها شروع به تخریب محیط زیست خود کرده‌اند و فراموش نموده‌اند که سالیان سال در آن زندگی کرده و از لحاظ بیولوژیکی بدان وابسته هستند. [۴] بر این اساس، در سال ۱۹۷۱ میلادی، عده‌ای از کارشناسان محیط زیست و توسعه آن در کشور سوئیس گرد آمدند و مسئله حمایت و بهبود محیط زیست را به‌عنوان اصل و نیازی فوری برای کشورهای درحال توسعه مطرح کردند. حال سؤال این است که چرا این امر، برای این کشورها مهم است؟

سطر با آغاز دهه ۱۹۵۰ میلادی، دولت‌های جوامع غربی و کشورهای صنعتی، مجموعه‌ای از داشته‌های جامعه خود را در قالب مجموعه‌ای به نمایش گذاشتند و اذعان داشتند با آنها مردمان این کشور به خوشبختی رسیده‌اند و می‌توانند آنها را به کشورهای فقیر یا تازه به استقلال رسیده آسیایی و آفریقایی صادر کنند تا آنها نیز آباد شوند. از طرف دیگر، کشورهای فقیر، هیچ‌کدام از چیزهای درون این مجموعه مانند بزرگراه، کارخانه‌ها، لوله‌کشی آب، جاده‌ها، مدرسه، دانشگاه، رستوران، هتل و ... را نداشتند و به آن، احساس نیاز می‌کردند و خواستار وارد کردن آن بودند. به‌واقع، توسعه منجر به ارتقا و بهبود سطح زندگی در بسیاری از زمینه‌ها مانند بهداشت، تغذیه، آموزش و درآمد کشورها شده است. با این حال، توسعه بدون تفکر و بی‌مبالات در کشورها، باعث به‌وجود آمدن مشکلاتی، هم در کشورهای پیشرفته و هم صنعتی شد و منجر به آلودگی آب، هوا و خاک گشت. [۱] اثرات این توسعه بی‌مبالات، آسیب‌های زیادی به محیط زیست و فرهنگ وارد آورده و منجر به تغییراتی اساسی در تفکرات و شیوه‌های زندگی افراد گشته است. در اینجا بود که بحث توسعه پایدار مطرح شد. (۲۵)

توسعه پایدار که دربرگیرنده تعامل میان انسان و محیط و انسان و انسان است، تنظیم و ساماندهی این رابطه را دربر دارد و براساس آنچه خود نتیجه تلاش‌های بسیاری بود، مطرح گشت. سه دسته از عوامل، منجر به رونق گرفتن تفکر توسعه پایدار شدند: نتایج بد کارکردی اجرای سیاست‌های تعدیل ساختاری که خود برای مقابله با بحران اقتصاد جهانی در

به صفحه بعد بروید.

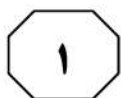
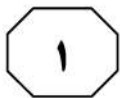
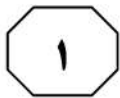

750 C



- ۴- کدام مورد، ساختار متن را به بهترین وجه توصیف می‌کند؟
- (۱) نظریه‌ای مطرح و سپس آن نظریه، در بستر تاریخی تغییر و تحول مربوطه قرار داده می‌شود.
- (۲) پیش‌زمینه‌ای برای موضوع متن مطرح می‌شود و سپس آن موضوع، مورد واکاوی دقیق‌تر قرار می‌گیرد.
- (۳) راهبردی مناقشه‌برانگیز مطرح و نظریه‌های موافق و مخالف با آن با هم مقایسه می‌شود و سپس قضاوتی نهایی به‌عمل می‌آید.
- (۴) معضلات حاصل از یک پدیده پرشمرده می‌شود و سپس راه‌کارهای بهینه‌سازی آن پدیده، مورد بحث و بررسی قرار می‌گیرد.
- ۶- اطلاعات کافی برای پاسخ به کدام پرسش، در متن وجود دارد؟
- (۱) مبحث توسعه پایدار چرا مطرح شد؟
- (۲) جلوه‌هایی از توسعه پایدار در بُعد رابطه انسان و انسان کدام‌اند؟
- (۳) آیا حفظ محیط زیست، مهم‌ترین مؤلفه توسعه پایدار محسوب می‌شود؟
- (۴) چرا در دهه پنجاه قرن بیستم، آبادی و توسعه معادل خوشبختی قلمداد می‌شد؟
- ۵- موضوع احتمالی پاراگراف بعد از متن، کدام است؟
- (۱) بررسی دلایل بی‌توجهی کشورهای درحال توسعه به راهکارهای مناسب در توسعه ملی
- (۲) ارزیابی روند توسعه پایدار در کشورهای درحال توسعه در دهه هفتاد قرن بیستم
- (۳) دلیل توجه کارشناسانی که در سال ۱۹۷۱ در سوئیس گرد آمدند، به مسئله زیست‌محیطی
- (۴) توضیح بیشتر درباره لزوم توجه به مسائل زیست‌محیطی در توسعه پایدار کشورهای درحال توسعه
- ۷- کدام محل در متن که با شماره‌های [۱]، [۲]، [۳] و [۴] مشخص شده‌اند، بهترین محل برای قرار گرفتن عبارت زیر است؟
- «این دیدگاه‌ها منجر به شروع اولین تحولات مربوط به سال ۱۹۷۱ میلادی شد و ویژگی آن، در رابطه با کیفیت محیط زیست در مقابل رشد اقتصادی و نگاه دوباره به الگوهای سنتی رشد اقتصادی بود.»
- (۱) [۱]
- (۲) [۲]
- (۳) [۳]
- (۴) [۴]

پایان بخش اول



بخش دوم

راهنمایی:

- این بخش از آزمون استعداد، از انواع مختلف سؤال‌های کمی، شامل مقایسه‌های کمی، استعداد ریاضیاتی، حل مسئله و ... تشکیل شده است.
- توجه داشته باشید به خاطر متفاوت بودن نوع سؤال‌های این بخش از آزمون، هر سؤال را براساس دستورالعمل ویژه‌ای که در ابتدای هر دسته سؤال آمده است، پاسخ دهید.



750 C



راهنمایی: هر کدام از سؤال‌های ۸ تا ۱۱ را به دقت بخوانید و جواب هر سؤال را در پاسخنامه علامت بزنید.

- ۸- تعدادی سیب قرار است به تساوی بین تعدادی کودک تقسیم شود. می‌دانیم اگر یک کودک کم شود، به هر کدام از کودکان دیگر، یک سیب بیشتر می‌رسد ولی اگر دو کودک اضافه شود، به هر کودک یک سیب کمتر می‌رسد. تعداد سیب‌ها کدام است؟
- ۱۰- حسن قرار است روی الگوی زیر، بدون اینکه از مسیر خط‌ها خارج شود و حتی از نقطه‌ای دو بار عبور کند، از نقطه A به نقطه B برود. طولانی‌ترین مسیر ممکن که حسن می‌تواند طی کند، چند برابر طول ضلع هر کدام از مربع‌های کوچک است؟

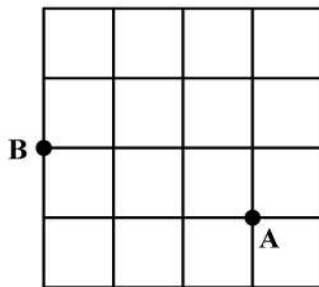

- (۱) ۱۲
(۲) ۱۸
(۳) ۲۰
(۴) ۲۴

- (۱) ۱۸
(۲) ۲۰
(۳) ۲۲
(۴) ۲۴

- ۹- در یک کفه از یک ترازوی دوکفه‌ای، ۱۰ قالب کره و در کفه دیگر آن، ۸ قالب پنیر قرار دارند و ترازو متعادل است. جای یک قالب پنیر را با یک قالب کره عوض می‌کنیم و یک کفه ترازو سنگین‌تر می‌شود. از کفه سنگین‌تر، چند درصد از یک قالب کره را باید برش داده و در کفه سبک‌تر قرار دهیم تا ترازو مجدداً متعادل شود؟

- (۱) ۲۰
(۲) ۲۵
(۳) ۴۰
(۴) ۵۰

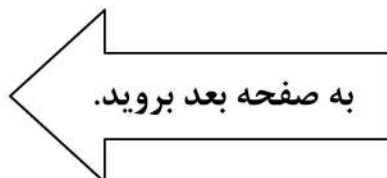



750 C



۱۱- محمد یک پنجره مربع شکل به ضلع ۹۰ سانتی متر که چارچوبش نصب شده است را می خواهد مطابق الگوی زیر، نرده کند. اگر وی بخواهد فاصله نرده ها از یکدیگر (هم عمودی و هم افقی) ۵ سانتی متر باشد، او به چند متر نرده نیاز دارد؟

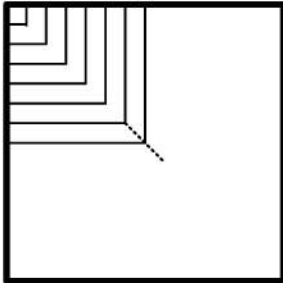

(۱) ۱۱٫۷

(۲) ۱۲٫۶

(۳) ۱۵٫۳

(۴) ۱۶٫۲

راهنمایی: هر کدام از سؤال های ۱۲ و ۱۳، شامل دو مقدار یا کمیت هستند، یکی در ستون «الف» و دیگری در ستون «ب». مقادیر دو ستون را با یکدیگر مقایسه کنید و با توجه به دستورالعمل، پاسخ صحیح را به شرح زیر تعیین کنید:

- اگر مقدار ستون «الف» بزرگ تر است، در پاسخنامه گزینه ۱ را علامت بزنید.

- اگر مقدار ستون «ب» بزرگ تر است، در پاسخنامه گزینه ۲ را علامت بزنید.

- اگر مقادیر دو ستون «الف» و «ب» با هم برابر هستند، در پاسخنامه گزینه ۳ را علامت بزنید.

- اگر براساس اطلاعات داده شده در سؤال، نتوان رابطه ای را بین مقادیر دو ستون «الف» و «ب» تعیین نمود، در پاسخنامه گزینه ۴ را علامت بزنید.

۱۳- یک نخ با طول نامعلوم که سرعت سوختن در سراسر آن ثابت است، در اختیار داریم. قرار است نخ را از نقاطی آتش بزنیم و مدت زمان سوختن کامل آن را اندازه بگیریم.

«ب»

مدت زمان سوختن کامل نخ، اگر آن را از دو نقطه که هر کدام از یک سر نخ، فاصله ای به اندازه ۳۰ درصد طول نخ دارند، همزمان آتش بزنیم

«الف»

مدت زمان سوختن کامل نخ، اگر آن را از دو سر و نقطه ای که طول نخ را به نسبت ۲ به ۳ تقسیم کند، همزمان آتش بزنیم

۱۲- عروسک فروشی، هر عروسک را با قیمت نامعلوم خریده و هر کدام را با x درصد سود به فروش می رساند. وی برای تبلیغ و فروش بهتر خود اعلام می کند که هر کس m عروسک بخرد، یک عروسک رایگان دریافت می کند.

«ب»

میزان سود نهایی فروشنده وقتی $x = 55$ و $m = 4$

«الف»

میزان سود نهایی فروشنده وقتی $x = 60$ و $m = 3$

پایان بخش دوم



بخش سوم

راهنمایی:

در این بخش، توانایی تحلیلی شما مورد سنجش قرار می‌گیرد. سؤال‌ها را به‌دقت بخوانید و پاسخ صحیح را در پاسخنامه علامت بزنید.



750 C



راهنمایی: با توجه به اطلاعات و شکل زیر، به سؤال‌های ۱۴ تا ۱۶ پاسخ دهید.

۱۵- اگر آجر D فقط با یک آجر در تماس باشد، جایگاه چند آجر از ۴ آجر دیگر، به‌طور قطع مشخص می‌شود؟

- (۱) ۴
(۲) ۲
(۳) ۱
(۴) صفر

کودکی توسط ۵ آجر A, B, C, D و E که یکی از آنها تیره است، سازه زیر را با گذاشتن سه آجر به‌طور عمودی و دو آجر به‌طور افقی ساخته است. درخصوص ساخت این سازه، اطلاعات زیر در دست است.

- آجرهای B و C، یکی به‌طور افقی و دیگری عمودی قرار گرفته‌اند و این اتفاق برای آجرهای D و E نیز رخ داده است.
- آجر A با آجر E در تماس است، ولی با آجر B در تماس نیست.
- آجرهای B و D، هیچ‌کدام تیره‌رنگ نیستند.

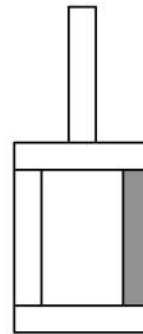

۱۶- اگر پایین‌ترین آجر B باشد، کدام آجر با سه آجر دیگر، در تماس است؟

- A I
D II
E III
- (۱) فقط II
(۲) II و III
(۳) فقط III
(۴) I و II

- (۱) A
(۲) C
(۳) D
(۴) E

به صفحه بعد بروید.



750 C



راهنمایی: با توجه به اطلاعات زیر، به سؤال‌های ۱۷ تا ۲۰ پاسخ دهید.

- ۱۸- اگر B یک فرش ۱۲ متری کرم خریده باشد، کدام مورد زیر درخصوص نام افراد و فرش‌هایی که خریده‌اند، صحیح نیست؟
- (۱) E و C - فرش‌های هم‌رنگ
 - (۲) B و C - فرش‌های هم‌رنگ
 - (۳) C و D - فرش‌های هم‌اندازه
 - (۴) A و D - فرش‌های هم‌اندازه
- پنج نفر به اسامی A، B، C، D و E برای خرید فرش به یک فروشگاه فرش مراجعه و هرکدام یک تخته فرش می‌خرند. فرش‌های فروشگاه در سایزهای ۶، ۹ و ۱۲ متری و در رنگ‌های لاکه و کرم عرضه می‌شوند. از ۵ فرش خریداری‌شده، ۲ عدد ۶ متری، ۲ عدد ۹ متری و ۱ عدد ۱۲ متری بوده است. اطلاعات زیر درخصوص سایز و رنگ فرش‌های خریداری‌شده موجود است:
- C، نه فرش ۹ متری خریده است و نه فرش هم‌رنگ فرش‌های خریداری‌شده توسط A و D.
 - فرشی که E خریده، از فرشی که A خریده، کوچک‌تر و هم‌رنگ فرش ۱۲ متری فروخته‌شده بوده است.
 - فرش‌های A و B، نه هم‌اندازه بوده‌اند و نه هم‌رنگ.
- ۱۷- اگر D یک فرش ۶ متری لاکه خریده باشد، کدام یک از فرش‌های زیر را خریده است؟
- (۱) ۹ متری کرم
 - (۲) ۶ متری کرم
 - (۳) ۹ متری لاکه
 - (۴) ۶ متری لاکه
- ۱۹- اگر D و E، فرش‌های کاملاً مشابهی خریده باشند، کدام مورد زیر درخصوص نام فرد و فرشی که خریداری کرده است، به‌طور قطع صحیح است؟
- (۱) B - فرش ۹ متری
 - (۲) C - فرش ۶ متری
 - (۳) E - فرش لاکه
 - (۴) A - فرش کرم
- ۲۰- اگر B از A فرش بزرگ‌تری آن‌هم به رنگ لاکه خریده باشد، چه کسی یک فرش ۶ متری کرم خریده است؟
- (۱) C
 - (۲) E
 - (۳) هیچ‌کس
 - (۴) B نمی‌تواند فرش لاکه بزرگ‌تر از فرش A خریده باشد.

پایان بخش سوم



بخش چهارم

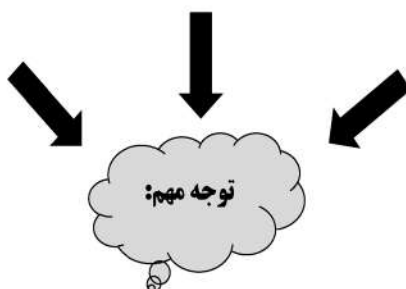

متقاضیان گرامی، در بخش چهارم، دو دسته سؤال داده شده است:

الف - استعداد منطقی - ویژه متقاضیان کلیه گروه‌های امتحانی به جز گروه امتحانی فنی و مهندسی
در بخش چهارم از آزمون استعداد تحصیلی، می‌بایست کلیه متقاضیان گروه‌های امتحانی هنر، زبان، علوم انسانی، کشاورزی و منابع طبیعی، دامپزشکی و علوم پایه، به جز متقاضیان گروه امتحانی فنی و مهندسی، فقط به سؤالات استعداد منطقی (سؤال‌های ۲۱ تا ۲۵) در صفحات ۱۳ تا ۱۶ پاسخ دهند.

ب - استعداد تجسمی - ویژه متقاضیان گروه امتحانی فنی و مهندسی
در این بخش، می‌بایست فقط متقاضیان گروه امتحانی فنی و مهندسی، به سؤالات استعداد تجسمی ویژه گروه امتحانی خود (سؤال‌های ۲۱ تا ۲۵) در صفحات ۱۷ تا ۲۰ پاسخ دهند.

الف - سؤالات استعداد منطقی ویژه متقاضیان کلیه گروه‌های امتحانی به جز گروه امتحانی فنی و مهندسی
(داوطلبان گروه فنی و مهندسی صرفاً به سؤال‌های صفحات ۱۷ تا ۲۰ پاسخ دهند.)

راهنمایی:

برای پاسخگویی به سؤال‌های این بخش، لازم است موقعیتی را که در هر سؤال مطرح شده، مورد تجزیه و تحلیل قرار دهید و سپس گزینه‌ای را که فکر می‌کنید پاسخ مناسب‌تری برای آن سؤال است، انتخاب کنید. هر سؤال را با دقت بخوانید و با توجه به واقعیت‌های مطرح‌شده در هر سؤال و نتایج که بیان شده و بیان نشده ولی قابل استنتاج است، پاسخی را که صحیح‌تر به نظر می‌رسد، انتخاب و در پاسخنامه علامت بزنید.



۲۲- محتوای کتب درسی و تمرین‌های آنها باعث شده است که معلمان نتوانند از روش‌های فعال تدریس استفاده کنند. تحلیل محتوای کتب درسی دوره دبیرستان نشان می‌دهد که تنها ۳۷ درصد معیارهای روش‌های تدریس فعال در کتب درسی این دوره اعمال شده است. بنابراین، معلمین خود اقدام به طراحی آموزش فعال محتوای کتب درسی می‌کنند تا شاگردان به درستی و کامل با مفاهیمی که ارائه می‌گردد، آشنا شوند و امکان برهم‌زدن نظم کلاس نیز از دانش‌آموزان خاطی سلب شود. با این وضع، ضروری است که محتوای کتب درسی با توجه به چگونگی آموزش و اعمال روش‌های تدریس فعال بازنگری گردد.

کدام مورد، فرض موجود در استدلال فوق است؟
 (۱) آنانی که کتب درسی دوره دبیرستان را طراحی کرده‌اند، اعتقادی به لزوم استفاده از روش‌های نوین آموزش نداشته‌اند.
 (۲) با اعمال تغییرات محتوایی در کتب درسی، می‌توان باعث ارتقای نمرات درسی دانش‌آموزان به‌طور معنی‌دار شد.

(۳) معلمین دبیرستان آشنایی لازم را با تهیه و تدوین تمرین‌های درسی براساس روش تدریس فعال دارند.

(۴) متخصصین تهیه و تدوین مواد درسی، به هنگام تهیه و تدوین مطالب مربوطه برای سطح دبیرستان، بهتر است با معلمین مربوطه همفکری کنند.

۲۱- مکالمات خیالی به معنی صحبت‌های خیالی در عالم واقع یا در عالم خواب از زبان اشخاص غیرواقعی، اشیا و یا حیوانات، سبک انتقادی نوینی بود که در مطبوعات دوره قاجار برای بیان انتقادهای سیاسی - اجتماعی نسبت به اقدامات دولت قاجار، به‌ویژه شخص محمدعلی شاه و دیگر مخالفان مشروطه، مورد استفاده قرار گرفته است. استفاده از این سبک، به‌دلیل الگوبرداری‌های متعدد مبانی سیاسی - اجتماعی موجود در مشروطه از گفتمان انقلاب کبیر فرانسه و روشنفکران تأثیرگذار بر آن انقلاب، به‌نظر می‌رسد براساس آشنایی با رویکردهای انتقادی فرنگ، مورد تقلید قرار گرفته است. این وجه نوین انتقادی، نخست در آثار کسانی چون ملک‌خان و آخوندزاده استفاده شد و پس از آن، مطبوعات فارسی‌زبان برون‌مرزی مانند اختر، قانون، ثریا، پرورش و حبل‌المتین، به‌دلیل عدم نظارت دولت قاجار، به استفاده از آن برای بیان انتقادهای خود پرداختند.

کدام مورد، در صورتی که صحیح فرض شود، به بهترین وجه، ادعای مربوط به بروز و استفاده از مکالمات خیالی در مطبوعات دوره قاجار را تضعیف می‌کند؟

(۱) کسانی که از این شیوه نگارشی استفاده کردند، با نمونه این شیوه نگارش که در ادبیات فارسی به‌صورت متون منشور و مسجع در قرون قبل وجود داشته است، کاملاً آشنا بودند.

(۲) مطبوعات فارسی‌زبان درون‌مرزی، به همان اندازه مطبوعات فارسی‌زبان برون‌مرزی، از شیوه مکالمات خیالی برای بیان مسائل اجتماعی استفاده می‌کردند.

(۳) بسیاری از روشنفکران انقلاب فرانسه، از شیوه‌های نگارشی تقلیدی استفاده می‌کردند.

(۴) استفاده از مکالمات خیالی، از قدرت کافی برای انتقاد سیاسی برخوردار نبود.

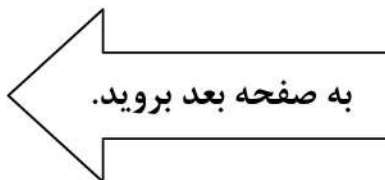



۲۴- برای بازنگریستن نهایی به آنچه در این سطور آمد، اینک به سخن آغازین درباره معنای عالم در زبان متداول فارسی برمی گردیم. عالمی که درباره هویت غربی - شرقی آن گفتیم، معنایش همان است که در زبان محاوره روزمره می گوئیم. این عالمی که ما آدمیان امروزمین برای خود ساخته ایم، در وهله اول، نشان غرب بر پیشانی دارد و در پی و در واکنش به آن است که، شرقی یا اسلامی یا ملی یا نظیر آنها می شود. و این، یعنی چنین هویتی، ثانوی است و عرضی. این عالم درعین حال، عالمی است مجازی، مجاز خود ماست و از هیچ جبر واقعی و نفس الامری بر نمی آید. پس چنین عالمی

کدام مورد، به منطقی ترین وجه، جای خالی در متن را کامل می کند؟

(۱) عناصر محتوایی قابل تجزیه و تحلیلی ندارد، چرا که از بنیان پوچ است

(۲) برهم زدنی و به هم خوردنی هم هست

(۳) حالا حالاها مسلط و چیره می ماند

(۴) غرب زدگی را هم با خود دارد

۲۳- در دیدگاه رفتارگرایان، انسان یک ارگانیسم تجربه گراست که استعداد بالقوه ای برای هر رفتاری دارد. به اعتقاد این گروه، انسان در بدو تولد، مانند لوح سفیدی است که هیچ چیزی بر آن نوشته نشده است. در این مکتب، هدف تعلیم و تربیت، تشکیل ذهن به وسیله ایجاد ارتباط و اتحاد میان محتویات ذهنی که به وسیله امور خارجی وارد ذهن شده است، می باشد. بنابر این نظریه، قوای ذهنی مثل حافظه، دقت و تفکر، ادراک و حتی احساسات عبارتند از ترتیبات و تداعی هایی که در اثر برخورد ذهن با عوامل و موقعیت های جدید به وجود آمده اند. جان لاک، جان استوارت میل، دیوید هیوم و جرج برکلی، به گسترش تجربه گرایی یاری رساندند. به اعتقاد آنها، معرفت واقعی از راه حواس حاصل می شود و ادراک تجربه حسی، تنها وسیله ارتباط انسان با واقعیت ها و جهانی است که او را دربر گرفته است.

کدام مورد، در صورتی که صحیح فرض شود، به بهترین وجه، دیدگاه رفتارگرایان را، آن گونه که در متن توصیف شده است، زیر سؤال می برد؟

(۱) حافظه، دقت و تفکر، ادراک و احساسات افراد مختلف، به خاطر تفاوت در شرایط زندگی و تجربیات مختلف، به شکل واحدی رشد و قوام نمی یابند.

(۲) برخی حامیان رفتارگرایی، برداشت درست و کاملی از تمامی اصول این مکتب ندارند.

(۳) امروزه روان شناسان بر این باورند که در صورت تلاش، شاید بتوان مکتب تعلیم و تربیتی جامع تر و متفاوت از رفتارگرایی فراهم آورد.

(۴) ثابت شده است که بسیاری از ادراکات و باورهای ذهنی افراد، ژنتیکی است و همراه آنها به دنیا می آیند.

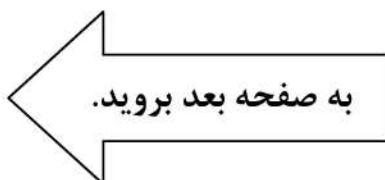



750 C



۲۵- یکی از علت‌های دیگر بروز تنبلی اجتماعی، این است که افراد حاضر در گروه، تصور می‌کنند دیگران سخت کار نمی‌کنند و لذا با احساس کم‌کاری سایرین، تنبلی خود را توجیه می‌کنند. گفته‌های کارکنان یک سازمان را در مواقعی که برای کم‌کاری زیر سؤال می‌روند، می‌توان در این قالب تفسیر کرد. برخی در پاسخ به این سؤال، مدعی هستند آنان که سخت کار می‌کنند، با آنهایی که تنبلی می‌کنند، در عمل تفاوتی ندارند. این پدیده «دلیل تراشی» نامیده می‌شود که به صورت غیرمستقیم، بر از بین بردن انگیزه پیشرفت مؤثر است که خود، از دلایل اساسی تنبلی اجتماعی در سازمان است. علت دیگر تنبلی اجتماعی، نبودِ وفاق سازمانی در سازمان یا گروه و یا عدم شناسایی سهم هر فرد در گروه و عدم نگرانی نسبت به ارزیابی شدن است؛ زیرا به میزانی که در گروه، ارزیابی و نظارت کاهش پیدا کند، به همان میزان هم تنبلی اجتماعی بالا می‌رود.

کدام مورد را می‌توان به درستی، از متن فوق استنباط کرد؟

- (۱) کار گروهی می‌تواند یک دلیل تنبلی اجتماعی باشد، چون در کار گروهی، مکانیسمی برای تعیین سهم واقعی هر فرد در تکمیل پروژه محوله وجود ندارد.
- (۲) دلیل اصلی عدم پیشرفت فردی کارکنان در سازمان‌هایی که مبتلا به تنبلی اجتماعی هستند، عدم نظارت کافی بر حسن انجام کار است.
- (۳) در جوامعی که تنبلی اجتماعی وجود دارد، همدلی سازمانی و حس مسئولیت‌پذیری کم می‌شود.
- (۴) تنبلی اجتماعی پدیده‌ای است که بروز و رشد آن، تحت تأثیر عوامل برون‌فردی قرار دارد.

پایان بخش چهارم

ویژه متقاضیان تمامی گروه‌های امتحانی به جز گروه امتحانی فنی و مهندسی



بخش چهارم

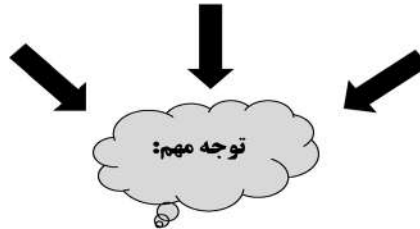

ب - استعداد تجسمی - ویژه متقاضیان گروه امتحانی فنی و مهندسی
در این بخش، فقط متقاضیان گروه امتحانی فنی و مهندسی، می‌بایست به سؤالات استعداد تجسمی (سؤال‌های ۲۱ تا ۲۵) در صفحات ۱۷ تا ۲۰ پاسخ دهند و متقاضیان سایر گروه‌های امتحانی (هنر، زبان، علوم انسانی، کشاورزی و منابع طبیعی، دامپزشکی و علوم پایه)، از پاسخگویی به سؤالات این بخش، اکیداً خودداری نمایند.

ب- استعداد تجسمی - ویژه متقاضیان گروه امتحانی فنی و مهندسی

(داوطلبان سایر گروه‌های امتحانی به جز فنی و مهندسی صرفاً به سؤال‌های صفحات ۱۳ تا ۱۶ پاسخ دهند)

راهنمایی:

این بخش از آزمون استعداد، سؤال‌هایی از نوع تجسمی را شامل می‌شود. هریک از سؤال‌های ۲۱ تا ۲۵ را به‌دقت بررسی نموده و جواب صحیح را در پاسخنامه علامت بزنید.



750 C



۲۱- در یک مکعب به ابعاد ۴ در ۴ در ۴، چند قطعه به شکل زیر را می توان جانمایی کرد؟

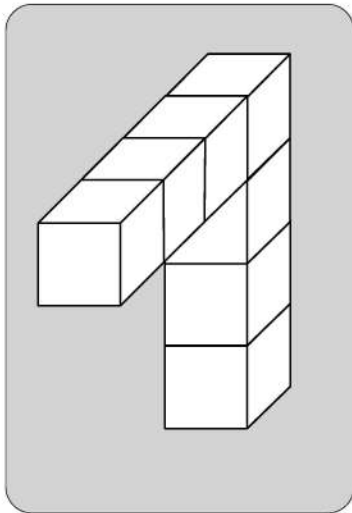

۸ (۱)

۷ (۲)

۶ (۳)

۴ (۴)

راهنمایی: در سؤال ۲۲، یک کاغذ مربع شکل در تصویر سمت چپ مشاهده می شود. اگر این کاغذ را از روی خط چین ها، رو به عقب و از روی خط ها، رو به جلو تا کنیم، کدام شکل حاصل می شود؟

۲۲-

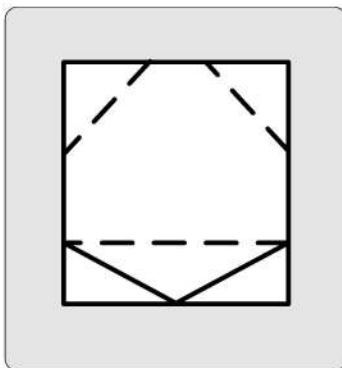

۱)

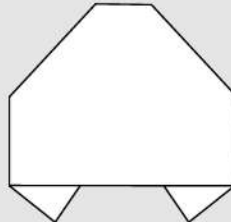

۲)

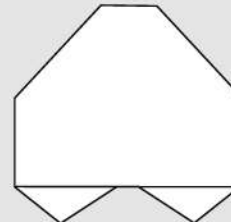

۳)

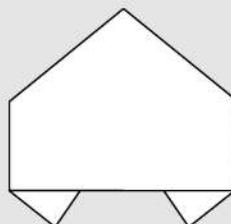

۴)

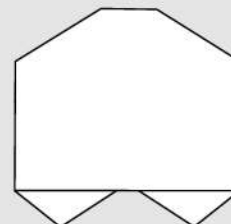

به صفحه بعد بروید.



750 C



۲۳- در شکل زیر، مجموعاً چند مثلث دیده می‌شود؟

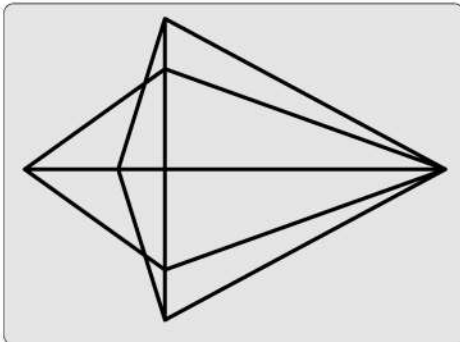

۲۲ (۱)

۲۴ (۲)

۲۶ (۳)

۲۸ (۴)

راهنمایی: در سؤال ۲۴، در سمت چپ، قطعه‌ای سه‌بعدی مشاهده می‌شود. کدام قطعه (موارد ۱ تا ۴) می‌تواند کنار قطعه سمت چپ قرار گیرد، به نحوی که نقاط سیاه دو قطعه، روی هم قرار گیرند؟

۲۴-

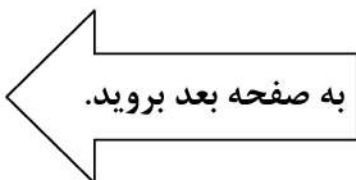
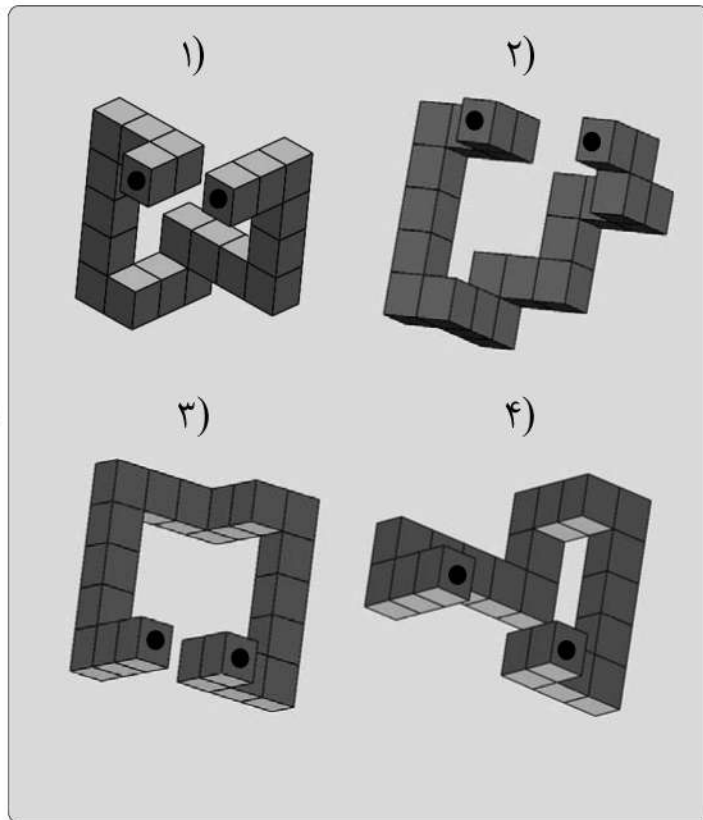
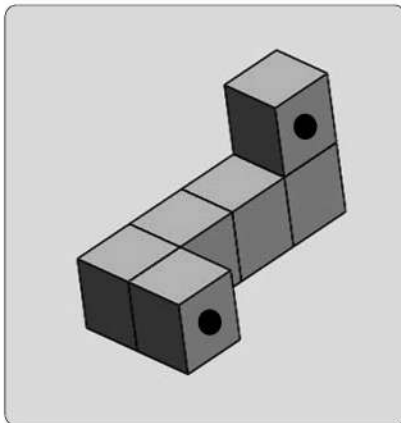



750 C



راهنمایی: در سؤال ۲۵، هر دو الگوی سمت چپ، قرار است با روالی مشابه و یکسان به الگوی سمت راست خود تبدیل شوند. به جای علامت سؤال، کدام الگو (موارد ۱ تا ۴) باید قرار بگیرد؟

۲۵-

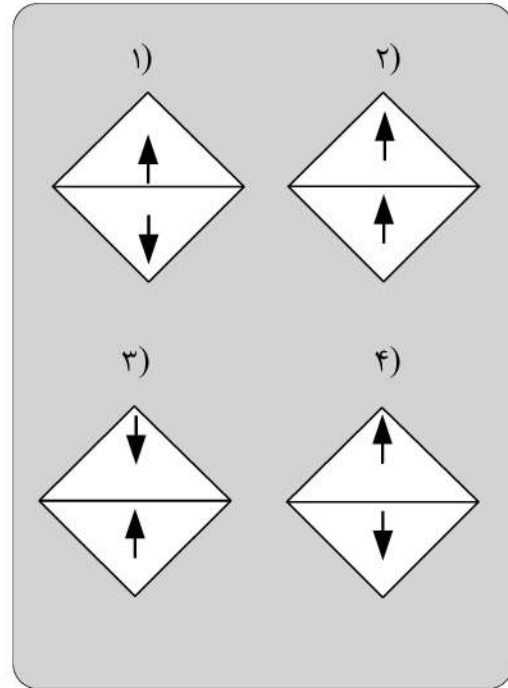
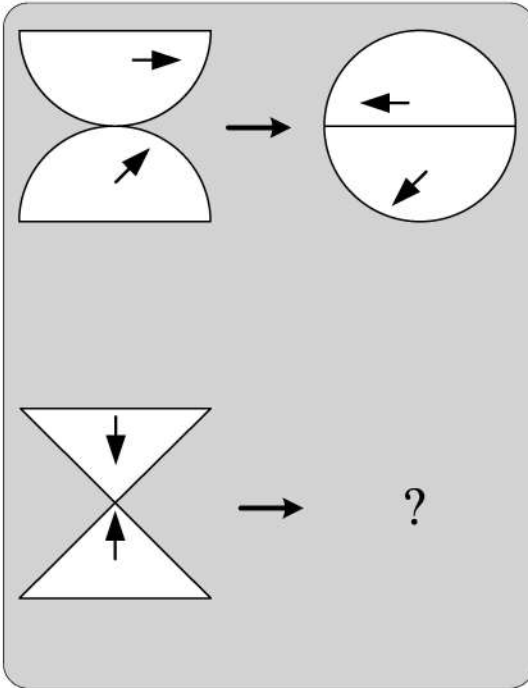

پایان بخش چهارم

ویژه متقاضیان گروه امتحانی فنی و مهندسی

کد کنترل

720

C



720C



جمهوری اسلامی ایران
وزارت علوم، تحقیقات و فناوری
سازمان سنجش آموزش کشور

«در زمینه مسائل علمی، باید دنبال قلّه بود.»
مقام معظم رهبری

عصر جمعه
۱۴۰۲/۱۲/۰۴

دفترچه شماره ۱ از ۳

آزمون ورودی دوره‌های دکتری (نیمه‌متمرکز) - سال ۱۴۰۳

زبان انگلیسی - عمومی

مدت زمان پاسخگویی: ۴۰ دقیقه

تعداد سؤال: ۴۰

عنوان مواد امتحانی، تعداد و شماره سؤال‌ها

ردیف	مواد امتحانی	تعداد سؤال	از شماره	تا شماره
۱	زبان انگلیسی - عمومی	۴۰	۱	۴۰

این آزمون، نمره منفی دارد.

استفاده از فرهنگ لغت مجاز نیست.

حق چاپ، تکثیر و انتشار سؤالات به هر روش (الکترونیکی و ...) پس از برگزاری آزمون، برای تمامی اشخاص حقیقی و حقوقی تنها با مجوز این سازمان مجاز می‌باشد و با متخلفین برابر مقررات رفتار می‌شود.

- 9- an economic downturn, the world's CEOs remain focused on seismic, long-term shifts within their businesses.
- 1) When the braces at
3) While bracing to
- 2) While braced for
4) When braced
- 10- It is not unanimous approval is needed for an extension, will agree.
- 1) a given that EU leaders, whose
3) a fact given by EU leaders that their
- 2) whom is given that EU leaders'
4) given the fact that of EU leaders, their
- 11- Most cash-strapped payers would the often sub-50% compliance rates for existing treatments than pay for a new, more expensive drug that may offer only incremental benefit.
- 1) prefer forking out a technology, showing improvement in
2) prefer forking out for a technology, which it improves
3) rather fork out for a technology shown to improve
4) rather a technology forked out that improve
- 12- Global temperatures human-caused warming and a climate pattern known as El Niño, forecasters at the World Meteorological Organization said on Wednesday.
- 1) that will likely soar to high records in the next five years, driving
2) which tend soaring to high records in the next five years, drove by
3) are likely to soar to record highs over the next five years, driven by
4) are likely soaring to record highs over the next five years, that drive
- 13- the point I was trying to make: that loneliness is a serious problem and that other countries are beginning to tackle it in ways that the U.S. should learn from.
- 1) Given the fact that the column, striking such a chord with readers, underscored
2) The fact that the column struck such a chord with readers underscored
3) The column striking such a chord with readers that it underscored
4) That the column struck such a chord with readers, underscoring
- 14- They have not yet delivered the robust economic expansion that normally follows recession, the crisis in 2007-2008.
- 1) neither have them put much of a dent in the debt burdens which sets off
2) and have they not put much of a dent in the debt burdens setting off
3) nor have they put much of a dent in the debt burdens that set off
4) they have nor put much of a dent in the debt burdens to set off

PART B: Vocabulary

Directions: Choose the word or phrase (1), (2), (3), or (4) that best completes each sentence. Then mark the answer on your answer sheet.

- 15- If you want to see the main commercial and business area of Tehran, you should go to the city
- 1) center
3) address
- 2) identity
4) audience
- 16- The two leaders agreed to attend a face-to-face meeting in order to social and political developments.
- 1) suffer
3) guess
- 2) miss
4) discuss
- 17- During Tuesday's meeting, the two politicians signed a new agreement that calls for closer cooperation in defense and security.
- 1) strategic
3) several
- 2) mental
4) crowded

- 18- **After the car, he is not able to walk and therefore needs a wheelchair to move around.**
 1) park 2) accident
 3) repair 4) vehicle
- 19- **She is and knowledgeable reporter who has traveled to several countries.**
 1) an extreme 2) a separate
 3) a confused 4) an experienced
- 20- **We all have a responsibility, and collectively, to be part of this titanic struggle for the renewal and rebirth of our continent.**
 1) formerly 2) theoretically
 3) individually 4) scarcely
- 21- **True is the desire to be useful to others with no thought of any reward.**
 1) charity 2) departure
 3) solemnity 4) contemplation
- 22- **In the ocean, water waves refract when they travel from deep water to water—or vice versa.**
 1) uncharted 2) potable
 3) shallow 4) excess
- 23- **When cooking the sauce, don't forget that all-important, fresh onion.**
 1) potion 2) desert
 3) combination 4) ingredient
- 24- **The conservative newspapers have tended to the extent of the problem.**
 1) solve 2) donate
 3) distract 4) understate
- 25- **An itch may be a common phenomenon, but science has barely begun to the surface of why an itch itches, and how to make it stop.**
 1) illuminate 2) scratch
 3) clarify 4) caress
- 26- **Unfortunately, some of the functions seem to be written with a fairly disregard for efficiency.**
 1) reckless 2) felicitous
 3) debilitated 4) seasonable
- 27- **Several major opportunities to cross-reference information were during the production of this encyclopedia and that means its value as a research tool is limited.**
 1) mandated 2) materialized
 3) squandered 4) vindicated
- 28- **Though Russia has refused to repatriate to Germany and other countries works of art and archeological treasures, President Boris Yeltsin, in a gesture, has returned cultural and diplomatic archives to Germany.**
 1) rapacious 2) propitiatory
 3) misogynistic 4) pileous
- 29- **During the boisterous late-night vote sessions that would eventually elect McCormick as speaker back in June, Mandy sat dutifully by the podium in the House chamber, taking notes and avoiding the schoolyard going on all around her.**
 1) pellucidity 2) placidity
 3) attenuation 4) fracas

- 30- The critics who exhausted the language of during her presidency, should have exercised restraint and, instead of denigrating her, provided her with constructive criticism.
- | | |
|----------------|-----------------|
| 1) fulmination | 2) equivocation |
| 3) ataraxia | 4) panache |

PART C: Reading Comprehension

Directions: Read the following two passages and answer the questions by choosing the best choice (1), (2), (3), or (4). Then mark the correct choice on your answer sheet.

PASSAGE 1:

Humans persistently fail to live up to the ideal of rationality. We make common errors in our decision-making processes and are easily influenced by irrelevant details. And when we rush to a decision without reasoning through all the evidence, we call this trusting our intuition. We used to think the absence of such human quirks made computers better, but recent research in cognitive science tells us otherwise. Humans appear to have two complementary decision-making processes, one slow, deliberate and mostly rational, the other fast, impulsive, and able to match the present situation to prior experience, enabling us to reach a quick conclusion. This latter mode seems to be key to making human intelligence so effective.

While it is deliberative and sound, the rational part requires more time and energy. Imagine that an oncoming car starts to drift into your lane; you need to act immediately: sound the horn, hit the brakes, or swerve, rather than start a lengthy computation that would determine the optimal but possibly belated act. Such shortcuts are also beneficial when there is no emergency. Expend too much brain power computing the optimal solution to details like whether to wear the dark blue or the midnight blue shirt, and you'll quickly run out of time and energy for the important decisions.

So should Artificial Intelligence (AI) incorporate an intuitive component? Indeed, many modern AI systems do have two parts, one that reacts instantly to the situation, and one that does more deliberative reasoning. Some robots, equipped with computers, have an intuitive component built with a "subsumption" architecture, in which the lowest layers of the system are purely reactive, and higher levels serve to inhibit the reactions and organize more goal-directed behavior. This approach has proved to be useful, for example, for getting a legged robot to walk through rough terrain, to name one particularly fascinating and promising development.

- 31- The word "persistently" in paragraph 1 is closest in meaning to
- | | |
|------------------|-----------------|
| 1) deliberately | 2) occasionally |
| 3) unfortunately | 4) continuously |
- 32- The underlined phrase "this latter mode" in paragraph 1 refers to the
- | | |
|-------------------|--------------------|
| 1) dualistic mode | 2) deliberate mode |
| 3) intuitive mode | 4) rational mode |
- 33- Which of the following best describes the author's attitude to the installation of an intuitive component in AI?
- | | |
|-----------------|---------------|
| 1) Approving | 2) Ironic |
| 3) Disapproving | 4) Frustrated |

- 34- **What does paragraph 2 mainly discuss?**
- 1) The merits of the deliberative part of the brain
 - 2) The significance of intuition for humans in different situations
 - 3) The evolution of one of the complementary modes of the human brain
 - 4) The way the human brain makes a decision to respond to an emergency
- 35- **The passage provides sufficient information to answer which of the following questions?**
- I. **How much more energy does the human brain's rational part require compared with the intuitive part?**
 - II. **Is the function of the intuitive decision-making process confined only to urgent situations?**
 - III. **What are the chances of an apocalyptic scenario being realized, where AI robots enslave mankind?**
- 1) Only I
 - 2) Only II
 - 3) Only III
 - 4) II and III

PASSAGE 2:

There is no thorough study of English Orientalism during the Romantic Age comparable to Samuel Chew's treatment of Islam in English literature of the Renaissance or Martha P. Conant's study of the Oriental tale in English literature of the eighteenth century. Contributions to such a study have of course been made: Edna Osborne's "Oriental Diction and Theme in English Verse 1740-1840," Wallace C. Brown's several articles on the Near East in English literature of about the same period, and Harold Wiener's analysis of Byron's "Turkish Tales." The present article is concerned primarily with the Persian element in that Oriental complex—a limitation which is perhaps justified by the pre-eminence of Persian poetry over the poetry of other Asiatic nations as an influence upon English literature of this period.

What distinguishes the Orientalism of the Romantic Age from the earlier manifestations is that the last quarter of the eighteenth century saw the establishment, in England, of a genuine, firsthand study of the languages of Persia, Arabia, Turkey, and India. This enabled English writers to deal with original Oriental works, or at least with direct translations of them into English. By contrast, the Renaissance Englishman had known of the East almost exclusively through travel books written by men unfamiliar with the languages of the countries they visited. The early Enlightenment had learned about the literature of Asia, to be sure, but only by way of French and Latin versions of it, or through imitations of those versions inspired by the success of Galland's translation of the Arabian Nights. The true beginnings of Oriental studies in England are to be found in the work of Sir William Jones from about 1770 to his death in 1794, and in the uses to which his philological and literary researches were put by the agents of the East India Company when that enterprise was brought more closely under the British Crown by the India Act of 1784.

The interrelation of Jones's at first academic linguistic studies with the practical application of them following the change of status of the Indian empire is well illustrated by the different fate that befell the Oriental investigations of Thomas Gray a generation earlier. Shortly after the year 1755, Gray had written a pair of essays on India and Persia, based upon such Oriental learning as could then be garnered from the European languages, both ancient and modern. But these essays were not published until 1814.

- 36- The underlined word “exclusively” in paragraph 2 is closest in meaning to
- 1) alternatively
 - 2) potentially
 - 3) solely
 - 4) surprisingly
- 37- According to the passage, which of the following figures was a translator?
- 1) Galland
 - 2) Byron
 - 3) Thomas Gray
 - 4) Wallace C. Brown
- 38- According to paragraph 1, which of the following statements is true?
- 1) Scholarship is silent on the subject of English Orientalism during the Romantic Age.
 - 2) Edna Osborne’s work is an important piece written about English poetry, in which she studied her contemporary 18th-century English poets.
 - 3) Martha P. Conant’s study of the Oriental tale in English literature is one of the two most important works regarding English Orientalism during the Romantic period.
 - 4) Compared with the topic of Islam in English literature of the Renaissance, English Orientalism during the Romantic Age is a relatively under-addressed subject.
- 39- Which of the following factors best justifies the article’s limited scope, mentioned in paragraph 1?
- 1) The inadequacy of present scholarship, and the availability of new resources for research
 - 2) The comparatively significant role of Persian poetry as an influence on English literature in the Romantic period
 - 3) The new possibilities that opened up before oriental scholars to pursue their interests in academic spheres in an unprecedented manner
 - 4) The newly-found evidence of the interaction between oriental and occidental scholars
- 40- According to the passage, which of the following statements is true?
- 1) Thomas Gray wrote a pair of essays on India and Persia after 1755, which were published posthumously in 1814, under the supervision of Sir William Jones.
 - 2) Sir William Jones’s study was, in a sense, a turning point in oriental studies on account of his philological and literary researches in the second half of the 17th century.
 - 3) Inspired by the Latin and French translations of the Arabian Nights, a series of tales emerged in Europe during the enlightenment, which brought together different themes from European literary tradition.
 - 4) What makes the Orientalism of the Romantic Age distinct from its previous counterparts is a factor as a result of which English writers’ experience of original Oriental works in this period was less mediated by translation.

مشاهده کلید اولیه سوالات آزمون دکتری 1403

کلید اولیه آزمون دکتری سال 1403

به اطلاع می‌رساند، کلید اولیه سوالات که در این سایت قرار گرفته است، غیر قابل استناد است و پس از دریافت نظرات داوطلبان و صاحب نظران کلید نهایی سوالات تهیه و بر اساس آن کارنامه داوطلبان استخراج خواهد شد. در صورت تمایل می‌توانید حداکثر تا تاریخ 1402/12/20 با مراجعه به سامانه پاسخگویی اینترنتی (request.sanjesh.org) نسبت به تکمیل فرم "اعتراض به کلید سوالات" / "آزمون دکتری سال 1403" اقدام نمایید.
لازم به ذکر است نظرات داوطلبان فقط تا تاریخ مذکور و از طریق فرم ذکر شده دریافت خواهد شد و به موارد ارسالی از طریق دیگر (نامه مکتوب یا فرم عمومی در سامانه پاسخگویی و ...) یا پس از تاریخ اعلام شده رسیدگی نخواهد شد.

عنوان دفترچه	نوع دفترچه	شماره پاسخنامه	گروه امتحانی
آموزش زبان و ادبیات انگلیسی	C	3	زبان

شماره سوال	گزینه صحیح	شماره سوال	گزینه صحیح	شماره سوال	گزینه صحیح	شماره سوال	گزینه صحیح	شماره سوال	گزینه صحیح	شماره سوال	گزینه صحیح
1	1	31	3	61	4	91	4	121	2	151	4
2	1	32	1	62	2	92	4	122	4	152	2
3	1	33	2	63	3	93	4	123	3	153	1
4	2	34	1	64	4	94	2	124	4	154	3
5	3	35	4	65	1	95	1	125	2	155	4
6	2	36	2	66	4	96	3	126	4	156	4
7	3	37	1	67	1	97	2	127	1	157	1
8	2	38	3	68	3	98	1	128	3	158	1
9	1	39	4	69	3	99	3	129	1	159	1
10	2	40	2	70	2	100	3	130	1	160	3
11	4	41	2	71	2	101	4	131	3	161	2
12	3	42	1	72	3	102	1	132	2	162	4
13	4	43	4	73	3	103	4	133	1	163	1
14	3	44	2	74	1	104	2	134	4	164	4
15	2	45	3	75	1	105	1	135	4	165	3
16	4	46	1	76	4	106	1	136	2	166	1
17	1	47	3	77	4	107	3	137	1	167	3
18	4	48	3	78	4	108	2	138	3	168	2
19	3	49	4	79	3	109	3	139	2	169	2
20	2	50	1	80	1	110	4	140	1	170	4
21	4	51	1	81	1	111	4	141	1	171	1
22	2	52	2	82	2	112	1	142	2	172	3
23	3	53	2	83	3	113	3	143	2	173	1
24	1	54	3	84	1	114	2	144	3	174	4
25	3	55	2	85	4	115	4	145	3	175	3
26	2	56	3	86	2	116	1	146	2	176	3
27	2	57	4	87	3	117	2	147	4	177	2
28	1	58	4	88	1	118	3	148	3	178	1
29	3	59	1	89	2	119	2	149	4	179	3
30	4	60	1	90	2	120	3	150	4	180	2
شماره سوال	گزینه صحیح	شماره سوال	گزینه صحیح								
181	4	211	2								
182	1	212	4								
183	2	213	1								
184	4	214	1								
185	4	215	3								
186	3										
187	2										
188	1										
189	2										
190	3										
191	1										
192	4										
193	3										
194	4										
195	2										
196	1										
197	3										
198	4										
199	3										
200	1										
201	2										
202	4										
203	1										
204	2										
205	4										
206	2										
207	1										
208	2										
209	4										
210	3										

خروج

رساند، کلید اولیه سوالات که در این سایت قرار گرفته است، غیر قابل استناد است و پس از دریافت نظرات داوطلبان و صاحب نظران کلید نهایی و بر اساس آن کارنامه داوطلبان استخراج خواهد شد. در صورت تمایل می توانید حداکثر تا تاریخ 1402/12/20 با مراجعه به سامانه پاسخگویی (request.sanjesh.o نسبت به تکمیل فرم "اعتراض به کلید سوالات" / "آزمون دکتری سال 1403" اقدام نمایید. است نظرات داوطلبان فقط تا تاریخ مذکور و از طریق فرم ذکر شده دریافت خواهد شد و به موارد ارسالی از طریق دیگر (نامه مکتوب یا فرم سامانه پاسخگویی و ...) یا پس از تاریخ اعلام شده رسیدگی نخواهد شد.

گروه امتحانی	شماره پاسخنامه	نوع دفترچه	ترتیب
استعدادفنی ومهندسی	2	C	مهندسی

شماره سوال	گزینه صحیح
1	4
2	1
3	3
4	2
5	4
6	1
7	4
8	1
9	2
10	4
11	3
12	2
13	3
14	4
15	2
16	1
17	1
18	3
19	2
20	3
21	3
22	1
23	2
24	4
25	1

خروج

رساند، کلید اولیه سوالات که در این سایت قرار گرفته است، غیر قابل استناد است و پس از دریافت نظرات داوطلبان و صاحب نظران کلید نهایی و بر اساس آن کارنامه داوطلبان استخراج خواهد شد. در صورت تمایل می توانید حداکثر تا تاریخ 1402/12/20 با مراجعه به سامانه پاسخگویی (request.sanjesh.org) نسبت به تکمیل فرم "اعتراض به کلید سوالات" / "آزمون دکتری سال 1403" اقدام نمایید. است نظرات داوطلبان فقط تا تاریخ مذکور و از طریق فرم ذکر شده دریافت خواهد شد و به موارد ارسالی از طریق دیگر (نامه مکتوب یا فرم سامانه پاسخگویی و ...) یا پس از تاریخ اعلام شده رسیدگی نخواهد شد.

ترتیب	نوع دفترچه	شماره پاسخنامه	گروه امتحانی
-عمومی	C	1	زبان انگلیسی - عمومی

شماره سوال	گزینه صحیح	شماره سوال	گزینه صحیح
1	3	31	4
2	1	32	3
3	2	33	1
4	2	34	2
5	4	35	2
6	1	36	3
7	3	37	1
8	4	38	4
9	2	39	2
10	1	40	4
11	3		
12	3		
13	2		
14	3		
15	1		
16	4		
17	1		
18	2		
19	4		
20	3		
21	1		
22	3		
23	4		
24	4		
25	2		
26	1		
27	3		
28	2		
29	4		
30	1		

